

aramco

F¹ in Schools

WORLD FINALS



TECHNICAL REGULATIONS 23

CONTENTS

TECHNICAL REGULATIONS	5
HELP TEXT	5
ARTICLE T1 – DEFINITIONS	7
T1.1 F1® IN SCHOOLS CAR.....	7
T1.2 FULLY ASSEMBLED CAR.....	8
T1.3 BODY	8
T1.4 POWER UNIT CARTRIDGE CHAMBER	8
T1.5 WING.....	9
T1.6 WING SUPPORT STRUCTURE	10
T1.7 NOSE CONE	10
T1.8 WHEEL	10
T1.9 WHEEL SUPPORT SYSTEM	10
T1.10 TETHER LINE GUIDE	10
T1.11 SURFACE FINISH AND DECALS.....	10
T1.12 F1® IN SCHOOLS LOGO DECAL	11
T1.13 HAND FINISHING.....	11
T1.14 OFFICIAL F1® MODEL BLOCK	11
T1.15 ENGINEERING DRAWINGS	11
T1.16 RENDERINGS.....	12
T1.17 REFERENCE PLANES.....	12
T1.18 ADDITIONAL COMPONENTS	13
T1.19 NORMAL.....	13
T1.20 FULL 8 GRAM POWER UNIT CARTRIDGE.....	13
T1.21 HALO	14
ARTICLE T2 – GENERAL PRINCIPLES	15
T2.1 REGULATIONS DOCUMENTS	15
T2.2 INTERPRETATION OF THE REGULATIONS	15
T2.3 AMENDMENTS TO THE REGULATIONS	15
T2.4 CLASSIFICATION OF REGULATIONS	15
T2.5 COMPLIANCE WITH REGULATIONS	15
T2.6 DESIGN IDEAS AND REGULATION COMPLIANCE QUESTIONS	16
T2.7 MEASUREMENTS	16
T2.8 BENEFIT OF DOUBT.....	17
T2.9 SPIRIT OF THE COMPETITION	17
T2.10 ORIGINALITY OF WORK	17
ARTICLE T3 – FULLY ASSEMBLED CAR	19
T3.1 DESIGN AND MANUFACTURE – [GENERAL PENALTY – 5PTS EACH]	19
T3.2 SAFE CONSTRUCTION [SAFETY PENALTY – 10PTS EACH].....	19
T3.3 UNDEFINED FEATURES – [PERFORMANCE PENALTY – 20PTS]	19
T3.4 TOTAL WIDTH – [GENERAL PENALTY – 5PTS PER MILLIMETRE]	19
T3.5 TOTAL HEIGHT – [GENERAL PENALTY – 5PTS PER MILLIMETRE]	19
T3.6 TOTAL WEIGHT – [PERFORMANCE PENALTY – 10PTS PER GRAM]	20
T3.7 TRACK CLEARANCE – [GENERAL PENALTY – 10PTS PER MILLIMETRE].....	20

T3.8	STATUS DURING RACING - [GENERAL PENALTY – 5PTS]	20
T3.9	REPLACEMENT COMPONENTS [GENERAL]	20
ARTICLE T4 – BODY		22
T4.1	BODY CONSTRUCTION – [GENERAL PENALTY – 20PTS].....	22
T4.2	VIRTUAL CARGO – [PERFORMANCE PENALTY – 25PTS]	22
T4.3	VIRTUAL CARGO IDENTIFICATION – [GENERAL PENALTY – 5 PTS].....	23
T4.4	HALO	23
T4.5	HELMET – [GENERAL PENALTY – 5PTS].....	24
T4.6	F1® IN SCHOOLS LOGO DECAL LOCATION – [GENERAL PENALTY – 5PTS].....	25
T4.7	TEAM NUMBER – [GENERAL PENALTY – 2PTS].....	25
T4.8	DECAL THICKNESS – [GENERAL PENALTY – 5PTS]	25
ARTICLE 5 – POWER UNIT CARTRIDGE CHAMBER		26
T5.1	DIAMETER – [SAFETY PENALTY – 5PTS]	26
T5.2	DISTANCE FROM TRACK SURFACE – [GENERAL PENALTY – 5PTS PER MILLIMETRE].....	26
T5.3	DEPTH – [SAFETY PENALTY – 5PTS]	26
T5.4	MAX ANGLE OF CHAMBER – [SAFETY PENALTY – 5PTS].....	26
T5.5	CHAMBER SAFETY ZONE – [SAFETY PENALTY – 10PTS].....	26
T5.6	POWER UNIT CARTRIDGE VISIBILITY – [PERFORMANCE PENALTY – 10PTS PER MILLIMETRE]	27
ARTICLE T6 – TETHER LINE GUIDES.....		28
T6.1	LOCATION – [SAFETY PENALTY – 10PTS]	28
T6.2	INTERNAL DIMENSION – [SAFETY PENALTY – 5PTS]	28
T6.3	TETHER LINE GUIDE SAFETY – [SAFETY PENALTY – 10PTS]	29
ARTICLE T7 – WHEELS AND WHEEL SUPPORT STRUCTURES		30
T7.1	NUMBER AND LOCATION – [GENERAL PENALTY – 25PTS].....	30
T7.2	DISTANCE BETWEEN OPPOSING WHEELS – [PERFORMANCE PENALTY – 2.5PTS PER MILLIMETRE PER AXLE].....	30
T7.3	WHEELBASE – [PERFORMANCE PENALTY – 5PTS PER MILLIMETRE].....	30
T7.4	TRACK CONTACT WIDTH – [PERFORMANCE PENALTY – 2.5PTS PER MILLIMETRE PER WHEEL]	31
T7.5	DIAMETER – [PERFORMANCE PENALTY – 2.5PTS PER MILLIMETRE PER WHEEL].....	31
T7.6	RACE TRACK CONTACT – [PERFORMANCE PENALTY – 2.5PTS PER WHEEL].....	31
T7.7	ROLLING SURFACE – [PERFORMANCE PENALTY – 2.5PTS PER WHEEL]	31
T7.8	ROTATION – [PERFORMANCE PENALTY – 5PTS PER WHEEL]	31
T7.9	VISIBILITY IN TOP AND BOTTOM VIEWS – [PERFORMANCE]	32
T7.10	VISIBILITY IN SIDE VIEWS – [PERFORMANCE PENALTY – 10PTS PER WHEEL]	33
T7.11	VISIBILITY IN FRONT VIEW – [PERFORMANCE PENALTY – 10PTS PER MILLIMETRE].....	33
T7.12	WHEEL SUPPORT – [GENERAL PENALTY – 5PTS EACH]	33
T7.13	WHEEL SAFETY TEST [SAFETY PENALTY – 2.5PTS PER WHEEL].....	34
ARTICLE T8 – NOSE, FRONT WING AND WING SUPPORT STRUCTURES		35
T8.1	NOSE, FRONT WING AND WING SUPPORT STRUCTURE IDENTIFICATION – [GENERAL PENALTY – 5PTS].....	35
T8.2	NOSE CONE ASSEMBLY DIMENSION - [GENERAL PENALTY – 5PTS EACH].....	35
T8.3	FRONT WING(S) DESCRIPTION AND PLACEMENT – [GENERAL PENALTY – 5PTS].....	35
T8.4	FRONT WING(S) CONSTRUCTION AND RIGIDITY – [GENERAL - PENALTY – 5PTS].....	35
T8.5	FRONT WING AND WING SUPPORT STRUCTURE LOCATION – [GENERAL - PENALTY – 10PTS]	36
T8.6	FRONT WING DIMENSIONS – [PERFORMANCE].....	37
T8.7	FRONT WING CLEAR AIRFLOW - [PERFORMANCE PENALTY – 5PTS]	39

T8.8 FRONT WING VISIBILITY – [PERFORMANCE | PENALTY – 10PTS]40

T8.9 NOSE CONE REPLACEMENT CHALLENGE (OPTIONAL) [GENERAL].....40

ARTICLE T9 – REAR WING AND WING SUPPORT STRUCTURES. 41

T9.1 REAR WING AND WING SUPPORT STRUCTURE IDENTIFICATION – [GENERAL – PENALTY – 5PTS]41

T9.2 REAR WING DESCRIPTION AND PLACEMENT – [GENERAL - PENALTY – 5PTS]41

T9.3 REAR WING CONSTRUCTION AND RIGIDITY – [GENERAL PENALTY – 5PTS]41

T9.4 REAR WING AND WING SUPPORT STRUCTURE LOCATION – [GENERAL – PENALTY – 10PTS].....41

T9.5 REAR WING DIMENSIONS – [PERFORMANCE]42

T9.6 REAR WING CLEAR AIRFLOW – [PERFORMANCE | PENALTY – 5PTS]44

T9.7 REAR WING VISIBILITY – [PERFORMANCE | PENALTY – 10PTS]45

ARTICLE T10 – ADDITIONAL COMPONENTS..... 45

T10.1 DESCRIPTION AND PLACEMENT [GENERAL]45

APPENDIX – OTHER INFORMATION & ILLUSTRATIONS..... 47

I. START BOX AND FINISH GATE.....47

II. OFFICIAL F1® MODEL BLOCK DIMENSIONS.....48

III. FRONT WING COMPLIANCE EXAMPLES49

IV. REAR WING COMPLIANCE EXAMPLES51

V. WING OVERLAP53

VI. OFFICIAL DENFORD RACE POWER PACK DIMENSIONS.....54

VII. CAR DECELERATION SYSTEM DIMENSIONS.....54

VIII. EXAMPLE OF COMPONENT IDENTIFICATION FROM 2021 WORLD CHAMPIONS CAR.....55

IX. HALO DRAWINGS56

Please note: any amendments made prior to the event will be indicated using red underlined text.

TECHNICAL REGULATIONS

Please read the whole document without assumptions from previous rules documents.

HELP TEXT

When you see green italic text, this is intended to help clarify a regulation or diagram.

When you see the PP+ symbol in the margin, this means a rule carries a Proportional Penalty. Find out more about Proportional Penalties and the classification of rules in T2.5.





TECHNICAL REGULATIONS

Definitions:	07
General Principles:	15
Car Design: Compliance & Penalties:	18
Appendix:	46



ARTICLE T1 - DEFINITIONS

T1.1 F1® in Schools car

This is also referred to as ‘the car’. Designed and manufactured according to these regulations for the purpose of participating in races on the F1 in Schools track at the World Finals event, powered only by a single 8 grams power unit cartridge. F1 in Schools cars are designed to travel the 20-metre race and physical deceleration after crossing the finishing line.

An F1 in Schools car assembly must only consist of the following components:

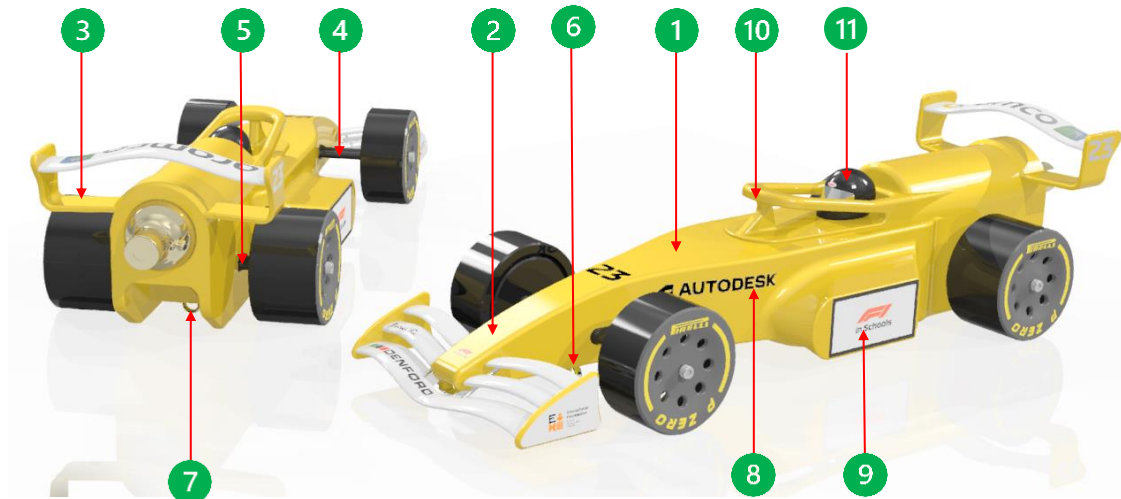

Adhesives with no dimensional impact are permissible for joining components.

Example parts:

	<ol style="list-style-type: none"> 1. A body encompassing a virtual cargo and a power unit cartridge chamber machined from a single piece of F1® Model Block Material
	<ol style="list-style-type: none"> 2. Nose cone assembly <ul style="list-style-type: none"> ○ Front wing support structure ○ Front wing(s) ○ End plates
	<ol style="list-style-type: none"> 3. Rear Wing Assembly <ul style="list-style-type: none"> ○ Rear wing support structure ○ Rear wing(s) ○ End plates
	<ol style="list-style-type: none"> 4. Front wheel support system(s) <ul style="list-style-type: none"> ○ Front wheel(s) rotating. ○ Wheel support structure non rotating

	<p>5. Rear wheel support system(s)</p> <ul style="list-style-type: none"> ○ Rear wheel(s) rotating. ○ Wheel support structure non rotating
	<p>6. Front tether line guide</p>
	<p>7. Rear tether line guide</p>
	<p>8. Surface finishing and decals</p>
	<p>9. F1® in Schools Logo Decal (2)</p>
	<p>10. Halo</p>
	<p>11. Drivers Helmet</p>

T1.2 Fully assembled car

An F1 in Schools car, without a power unit cartridge inserted, presented ready for racing, resting on all four wheels on the track surface, free of any external force other than gravity.

T1.3 Body

The body is a single uninterrupted piece of F1® Model Block material existing rear of reference plane A and encompassing both the virtual cargo and power unit cartridge chamber. For dimensional purposes the body also includes any attached decals and surface finishes. Any F1® Model Block forward of reference plane A is not defined as body.

T1.4 Power unit cartridge chamber

The power unit cartridge chamber is a cylindrical clear space bounded around its inner circumference and one end by car body only. This is where the power unit cartridge is placed for racing.

T1.5 Wing

A wing on an F1 in Schools car is an aerodynamic feature that permits airflow around its minimum required chord surface including its features of a leading and trailing edge across its minimum required span width. A wing is dimensionally defined by the span, chord and thickness. The vertical cross-sectional shape of the wing, parallel to the direction of car travel, is referred to as an aerofoil.

Wing cross-section / aerofoil naming terminology:

Wing naming terminology applied to single vane wing

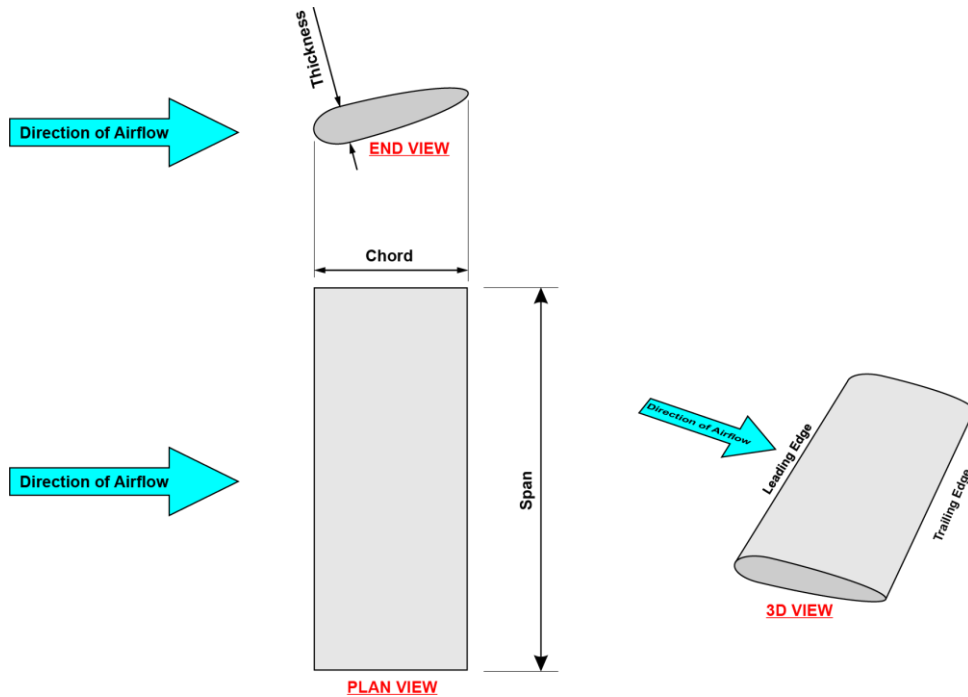

Wing naming terminology applied to multiple vane wing

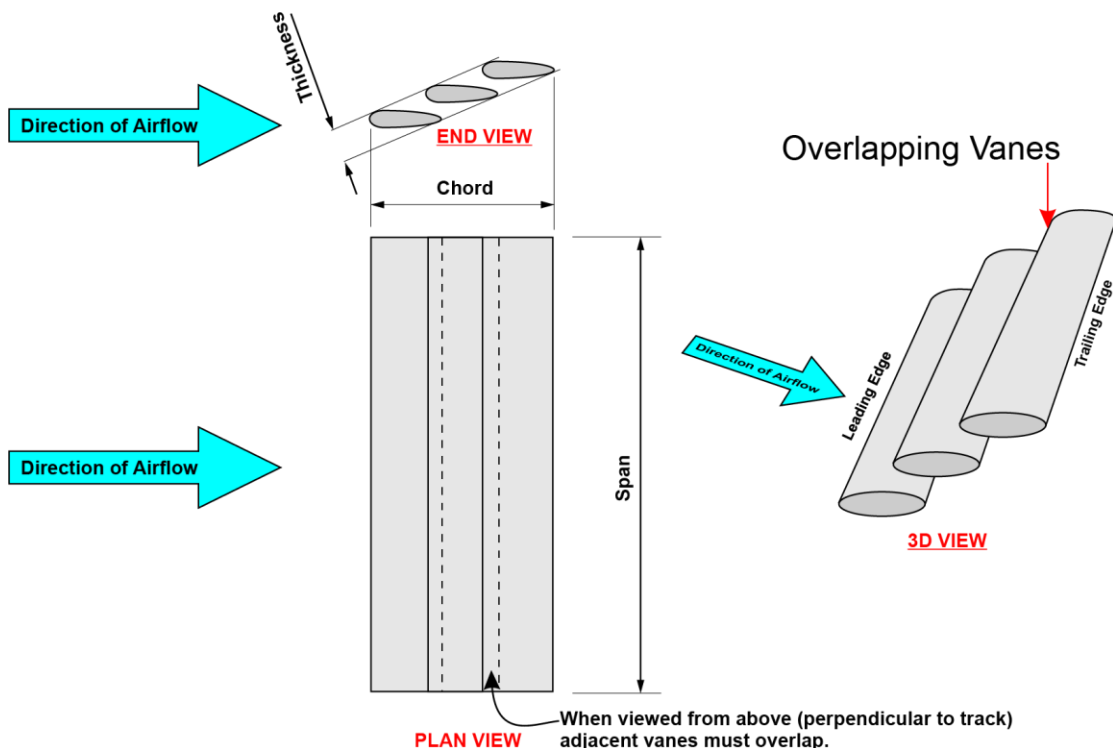

T1.6 Wing support structure

A wing support structure is a feature forward of reference plane A, that joins a wing(s) to the nose cone.

T1.7 Nose cone

The nose cone is a component of the car, which is used as a wing support structure, that only exists forward of reference plane A. This includes any F1® Model Block material or any other materials that continue forward of reference plane A.



T1.8 Wheel

A wheel is a single part or assembly of components, cylindrical in form, with its maximum circumference contacting the track surface, allowing forward motion of the car through rotation. All material existing within the volume of the actual wheel diameter and actual wheel width is considered to be part of the wheel.

T1.9 Wheel support system

Wheel support systems are single parts or an assembly of components that connect a wheel to any other part of the car, they MUST be contained within a theoretical cylindrical extrusion defined by the actual diameter of the relative wheels across each axle. These may be sourced from a supplier or manufactured wholly or in part by the team.

T1.10 Tether line guide

A tether line guide is a key safety component which completely surrounds the track tether line so as to safely connect the car to the tether line during races. A tether line guide can be a component sourced from a supplier or manufactured wholly or in part by the team.

T1.11 Surface finish and decals

A surface finish on an F1 in Schools car is considered to be any applied visible surface covering, of uniform thickness over the profile of an F1 in Schools car assembly component. A decal is material adhered to a component or surface finish. To be defined as a decal, 100% of the area of the adhering side must be attached to a surface. Surface finishes and decals are included when measuring the dimensions of any components they feature on.

T1.12 F1® in Schools logo decal

Teams must use a labelled decal to identify Car A and Car B and a blank decal to identify display car(s). The official decals are supplied by F1 in Schools Ltd at event registration.

This consists of the F1 in Schools logo graphic printed on a black or a white adhesive vinyl with a 1mm contrast keyline border, with a horizontal dimension of 30mm and vertical dimension of 15mm. Teams choose to use either the black or white outlined decal so as to provide maximum contrast to the surface colour the decal is being adhered to.

A team can manufacture and fit their own decals, provided they use the official F1 in Schools logo decal artwork which can be downloaded from the F1 in Schools website:



<https://www.f1inschools.com/downloads.html>

Decal designs:



T1.13 Hand finishing

Hand finishing is defined as use of a hand powered device (e.g. abrasive paper) for removing only the irregularities that may remain on a CNC machined surface of the car body. These irregularities are often referred to as 'machined marks', any hand finishing must be kept to a minimum.

T1.14 Official F1® Model Block

The official F1® Model Block Material is a rigid, closed cell foam block processed to the dimensional features as shown by diagrams in the appendix of this document.

IMPORTANT: all cars entered into the Aramco F1® in Schools World Finals 2023 must be manufactured from F1® Model Blocks. The official F1® Model Blocks can be sourced directly from Denford Limited or an official Denford Limited distributor.

T1.15 Engineering drawings

Engineering drawings are CAD produced drawings which should be detailed such that, along with relevant CAM programs, could theoretically be used to manufacture the fully assembled car by a third party. Such drawings **MUST** include all relevant dimensions and material information.

Where stated, F1 in Schools engineering drawings of a readable scale **MUST** be clearly dimensioned and identified by hatching, shading, block colour or boundary line within the engineering drawings to specifically identify and prove compliance for the virtual cargo, front and rear wheel support structures, nose, front and rear wing support structures and front and rear wing surfaces.

Clearly labelled construction or boundary lines are acceptable to define the boundaries between components such as nose cone, wheel support and wing support structures.

Engineering drawings can include: orthographic projection, auxiliary projection, section views, isometric projection, oblique projection, perspective and annotated renderings.

It is recommended to label the relevant technical regulations where appropriate (e.g **T9.5.1: 25.0mm**) throughout your Engineering drawings; this makes the job of the scrutineer much easier in identifying the different features of your car.

T1.16 Renderings

Renderings are images intended to illustrate the three-dimensional form of an object. These can be generated in isometric projection, oblique projection, or perspective.

T1.17 Reference Planes

T1.17.1 Vertical Reference Plane

To assist with describing dimensions, it is assumed that a two-dimensional invisible plane exists along the length of the power unit cartridge chamber centre axis and normal to the track surface. This is known as the vertical reference plane.

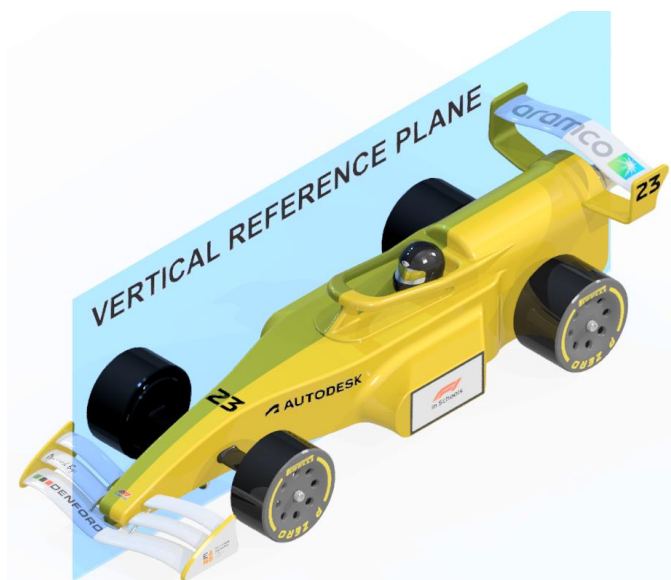

T1.17.2 Reference Plane A

To assist with describing dimensions, it is assumed that a two-dimensional invisible plane exists 16.0mm in front of the front axle centre line normal to the track surface. This is known as the reference plane A.



T1.17.3 Reference Plane B

To assist with describing dimensions, it is assumed that a two-dimensional invisible plane exists 16.0mm to the rear of the rear axle centre line normal to the track surface.

This is known as the reference plane B.



T1.18 Additional Components

Any component other than those listed in T1.1 will be considered an additional component.

T1.19 Normal

The term 'normal' can be used in geometry to describe a line or object that is perpendicular or at 90 degrees to another given object. When referring to the term normal in these regulations it is considered to mean:

- Being at right angles; perpendicular.
- Perpendicular to the direction of a tangent line of a curve or a tangent plane to a surface.

T1.20 Full 8 gram power unit cartridge

A metallic cartridge which contains an 8 gram charge of compressed air. For weights and dimensions refer to appendix v. Official Denford Race Power Pack dimensions.



T1.21 Halo

The halo is a driver crash-protection system used in open-wheel racing series, which consists of a curved bar placed to protect the driver's head. The Halo is being introduced to F1® in Schools not only to echo real F1® car design but also as a component of a new car deceleration system.

The Halo is available to download as a universal 3D part from the F1 in Schools website. For this part and more free downloads, please visit



<https://www.f1inschools.com/downloads.html>

The Halo **MUST** be included in the final car design. Detailed Engineering Drawings are available in appendix ix.

HALO – IMPACT PROTECTION SYSTEM

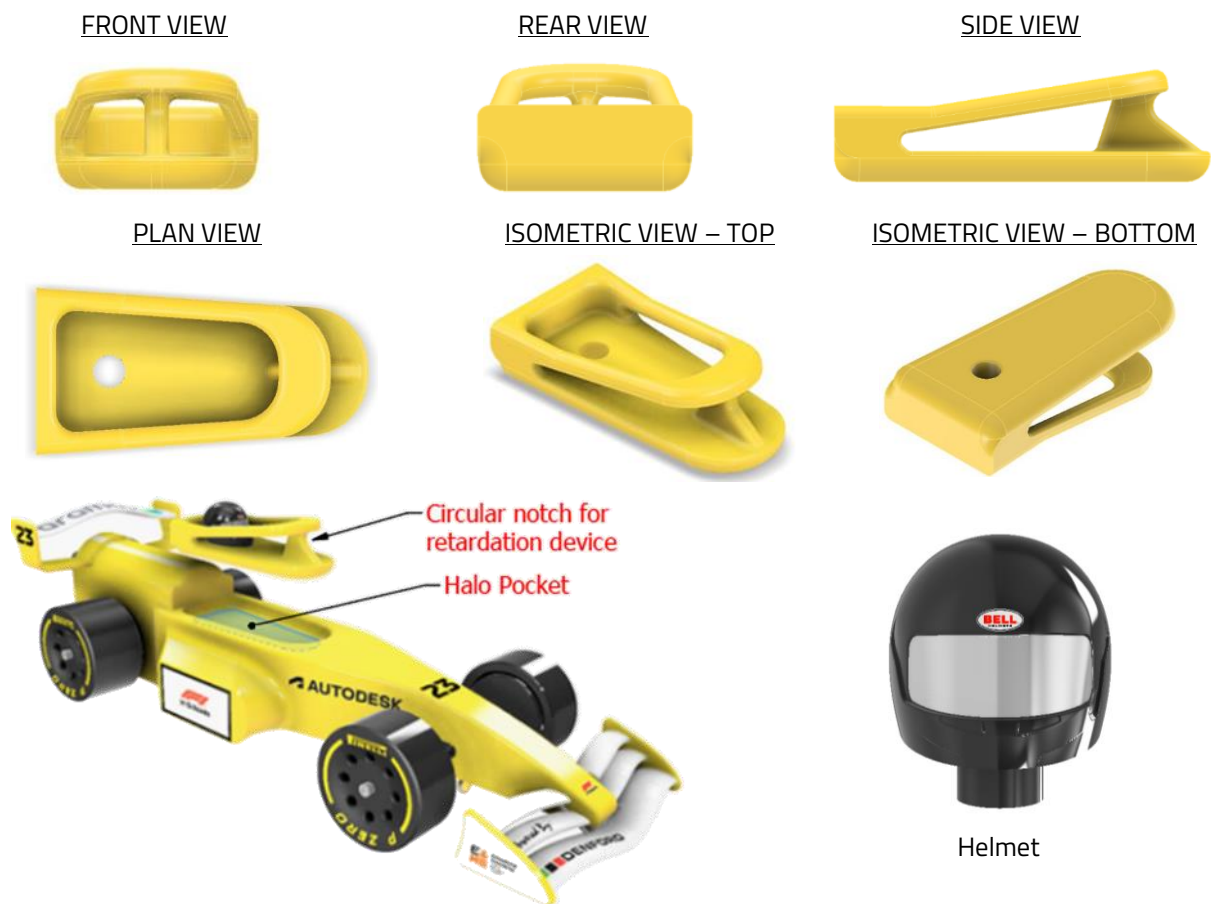

The Halo must be well adhered to the body of the car, to achieve this requires a recess or pocket to match the underside of the Halo in the car body. It has been designed so the required recess or pocket can be manufactured using a 1/4" (6.35mm) or smaller ball nose cutter. The Helmet is a mandatory item and can be made from any material. *Please see Appendix ix for further details.*

ARTICLE T2 - GENERAL PRINCIPLES

T2.1 Regulations documents

T2.1.1 F1 in Schools Ltd. issues the regulations, their revisions and amendments made.

T2.1.2 Technical Regulations - this document. The Technical Regulations document is mainly concerned with those regulations that are directly related to F1 in Schools car design and manufacture. Technical regulation article numbers have a 'T' prefix.

T2.1.3 Competition Regulations – a document separate to this one which is mainly concerned with regulations and procedures directly related to judging and the competition event. Competition Regulation article numbers have a 'C' prefix.

T2.2 Interpretation of the regulations

T2.2.1 The final text of these regulations is in English should any dispute arise over their interpretation. The text of a regulation and any related definitions should be considered together for the purpose of interpretation.

IMPORTANT: Diagrams and or images are for illustration purposes only and do not contribute to regulatory compliance.

T2.2.2 Text clarification - any questions received that are deemed by F1 in Schools Ltd. to be related to regulation text needing clarification will be answered by F1 in Schools Ltd. The question received, along with the clarification provided by F1 in Schools Ltd., will be published to all competing teams at the same time via the official F1 in Schools website: <https://www.f1inschools.com/clarifications-2023>.

T2.3 Amendments to the regulations

Any amendments will be announced and released by F1 in Schools Ltd. by email notification to all In-Country Coordinators (ICC) as well as being posted on the website www.f1inschools.com.

Any amended text will be indicated **thus** (using red underlined text).

T2.4 Classification of regulations

T2.4.1 The technical regulations are classified as either: **GENERAL**, **SAFETY**, **PERFORMANCE**.

GENERAL	SAFETY	PERFORMANCE
Regulations that shape the way the car fundamentally looks and works, vital to the style of an F1 in Schools car.	Mandatory rules that govern the safe running of the car. Cars must meet these rules to be considered 'safe to race'.	Rules that have a direct impact on the performance of the vehicle, these typically carry the heaviest penalties.

T2.4.2 If a race car is judged as being NON-COMPLIANT with any **Performance** regulation they will be **INELIGIBLE for the awards of: 'Fastest Car' and 'Best Engineered Car'**. All **Performance** regulations are highlighted in yellow throughout this document.

T2.5 Compliance with regulations

T2.5.1 Points are deducted for non-compliance with the technical regulations as per the penalties as defined in this document. Both race cars are assessed during Specification Judging and points will be deducted for any infringements on either car. These penalties are only applied once, per infringement, per car. After initial Specification Judging any team with technical infringements will be given a single 20 minute car service session. See competition regulations for more information.

T2.5.2 Proportional penalties will be applied to the following regulations:

T3.4, T3.5, T3.6, T3.7, T3.8, T5.2, T5.6, T7.2, T7.3, T7.4, T7.5, T7.11, T8.5, T9.5

The penalty applied increases proportionally as the margin of non-compliance with the absolute minimum/maximum dimension increases by rounding up the non-compliance to the next complete unit of measure (1.0mm or 1.0g). The penalty is applied once for every complete unit outside of the absolute minimum/maximum dimension. For example:

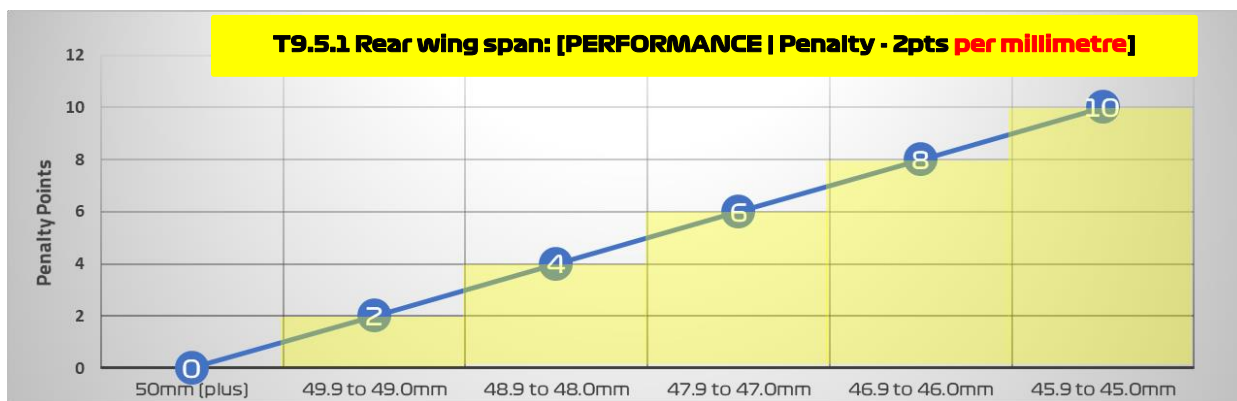

T2.6 Design ideas and regulation compliance questions

Teams are not permitted to seek a ruling from F1 in Schools Ltd. or any competition officials or judges before the event as to whether a design idea complies with these regulations, any regulatory communication between teams and ICCs or teachers is only for guidance, rulings will only be made by the official judges at the World Finals event. Design compliance to the regulations forms part of the competition. As in Formula 1® innovation is encouraged and F1 in Schools teams may also find ways of creating design features that push the boundaries of the regulations in order to get an extra competitive edge.

T2.7 Measurements

T2.7.1 All dimensions and weights are presented as absolute minimum or maximum, unless stated otherwise. For example:

MIN Weight	MIN Dimension	MAX Dimension
Absolute Min: 50.0g	Absolute Min: 26.0mm	Absolute Max: 34.0mm
50.0g - PASS	26.0mm - PASS	34.0mm - PASS
49.9g - FAIL	25.9mm - FAIL	34.1mm - FAIL

T2.7.2 Dimensional measures - all car component dimensions or weight are inclusive of any applied paint finish or decal. A series of specially manufactured gauges will be used to broadly verify dimensional compliance. Accurate measuring tools, such as vernier callipers, will then be used to closely inspect any dimensions found to be close to the dimensional limits per the initial gauge inspection. **IMPORTANT:** Some regulations are assessed with a full 8g race cartridge fully inserted into the cartridge chamber. For compliance with these regulations, the static weight distribution of the car must be such that the car is capable of **resting on all four (4)** wheels without any outside assistance.

T2.7.3 Weight measures – all weight measurements will be made using the F1 in Schools Ltd. calibrated electronic competition scales.

T2.8 Benefit of doubt

The chair of judges will, where appropriate, seek to use 'benefit of doubt' when the assessment of compliance is marginal or unclear. In this situation, teams will be given the benefit of doubt rather than a firm penalty if a penalty cannot be clearly measured or identified.

T2.9 Spirit of the competition

Teams are expected to act in the spirit of the competition, both before and during the F1 in Schools World Finals. Any team deemed by the chair of judges to be acting outside of the spirit of the competition, can be removed from certain or all aspects of the competition. For example, a team attempting to abuse the technical regulations to their advantage may, at the discretion of the chair of judges, be removed from racing and receive no points for this activity. A team deemed to be acting in an unsportsmanlike manner towards another team or other persons may be removed from some or all judging areas.

The spirit of the competition is simple; embrace and respect the rules and regulations, do your very best to compete legally and fairly, while contributing positively to the F1 in Schools World Finals. Make friends, create positive relationships, network professionally and enjoy yourselves.

T2.10 Originality of Work

F1 in Schools LTD welcomes and endorses innovation and does not consider that plagiarism should play any part in any of the disciplines that make up the competition.

Competing teams at all levels of the competition that intentionally plagiarise any part of their assessed work, undermines the credibility and integrity of the F1 in Schools challenge and the spirit of the competition. At the Aramco F1® in Schools World Finals 2023, F1 in Schools shall be implementing various originality detection methodologies and requesting all competing teams to submit an originality declaration.

Further details and associated penalties will be explained in detail in the Aramco F1® in Schools World Finals 2023 competition regulations.



CAR DESIGN: COMPLIANCE AND PENALTIES

Article T3:	Fully assembled car	19
Article T4:	Car body	22
Article T5:	Power unit cartridge chamber	26
Article T6:	Tether line guides	28
Article T7:	Wheels	30
Article T8:	Nose, Front Wings/support	35
Article T9:	Rear Wings/support	41
Article T10:	Additional Components	45



ARTICLE T3 - FULLY ASSEMBLED CAR

T3.1 Design and manufacture - [GENERAL | Penalty - 5pts each]

T3.1.1 All F1 in Schools cars must be designed and engineered using CAD (Computer Aided Design) and CAM (Computer Aided Manufacture) technology. CAD software used should provide for 3D part modelling, assembly and 3D realistic rendering. We recommend the use of Autodesk Fusion 360 software. The CAM package should allow students to simulate CNC machining processes so they can show evidence of these in their portfolio. We recommend the use of Denford QuickCAM PRO software.

T3.1.2 The body of all F1 in Schools cars must be manufactured via material removal using a CNC router/milling machine. We recommend all teams use a Denford CNC Router. This manufacturing process should occur at your school/college or at a designated manufacturing centre/partner site.

T3.1.3 An official F1 in Schools holographic sticker from the official F1® Model Block for each car must be submitted on the project element submission sheet at the World Finals event registration.

T3.1.4 The individual components of both race cars must be designed with identical geometry.

T3.2 Safe Construction [SAFETY | Penalty - 10pts each]

T3.2.1 Specification judging - all submitted cars will be inspected closely to ensure that they are engineered and constructed safely for the purpose of racing. If the judges rule an aspect of either race car to be unsafe for racing, the team will be required to carry out repairs / modifications to the car(s). Any such repair work will result in a penalty of 10 points per unsafe car.

T3.2.2 During racing – the race officials will routinely inspect cars for safety during scheduled races. If the officials rule a car to be unsafe, a penalty of 10 points will be imposed at the discretion of the Chair of Judges. The team may repair the car as per the Competition Regulations – C10 Car Repairs and Servicing.

T3.3 Undefined features - [PERFORMANCE | Penalty - 20pts]

The car assembly must only consist of components listed in ARTICLE T1.1.

T3.4 Total width - [GENERAL | Penalty - 5pts per millimetre]



Total width is the maximum assembled car width, measured normal to the vertical reference plane, between the outer edges of the widest feature of the car assembly.

Absolute Min: 65.0mm / Absolute Max: 85.0mm

T3.5 Total height - [GENERAL | Penalty - 5pts per millimetre]



Total height is the maximum assembled car height, normal to the vertical reference plane, between the track surface and the highest feature of the car assembly. This is measured with a full 8g power unit cartridge inserted into the cartridge chamber with the car sitting on all four (4) wheels with no outside assistance.

Absolute Max. 65.0mm

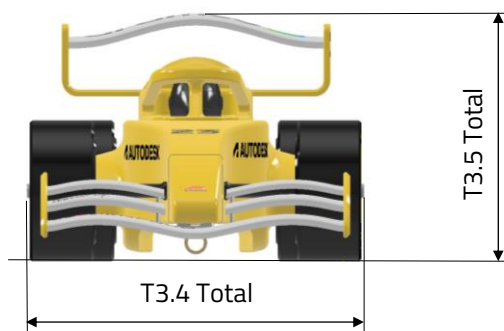

T3.6 Total weight - [PERFORMANCE | Penalty - 10pts per gram]



Total weight is the weight of the car excluding a power unit cartridge. If ruled underweight at registration or during initial scrutineering using the official competition scales, the above points penalty will be applied. No car will race underweight and ballast will be added to the underside of the car at 0.2g for every 0.1g underweight.

Absolute Min: 50.0g

T3.7 Track clearance - [GENERAL | Penalty - 10pts per millimetre]



Track clearance is the distance between track surface and any car component as listed in T1.1, except wheels. Measured normal to the track surface. This is measured with a full 8g power unit cartridge inserted into the cartridge chamber with the car sitting on all four (4) wheels with no outside assistance.

Absolute Min: 1.5mm

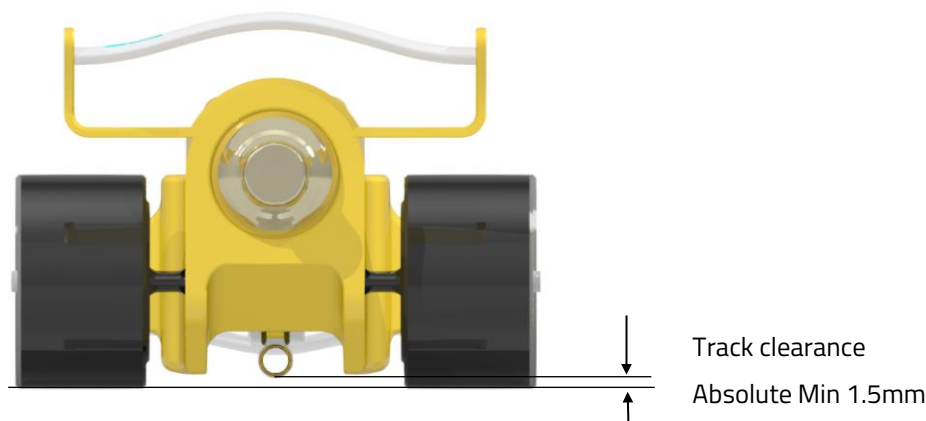

T3.8 Status during racing - [GENERAL | Penalty - 5pts]

The car assembly must be designed so that no items other than those listed in T3.9, or power unit cartridges are removed, replaced or added to the assembly during scheduled race events.

T3.9 Replacement Components [GENERAL]

Any spare / replacement components should be identical in design and geometry to those fitted to the car and must be submitted with the cars at registration. Only the following spare / replacement components are permitted:

Component	Max Quantity
Nose cone & front wing assembly	2
Rear wing assembly	2
Front wheels	4
Front wheel support structure	2
Rear wheels	4
Rear wheel support structure	2

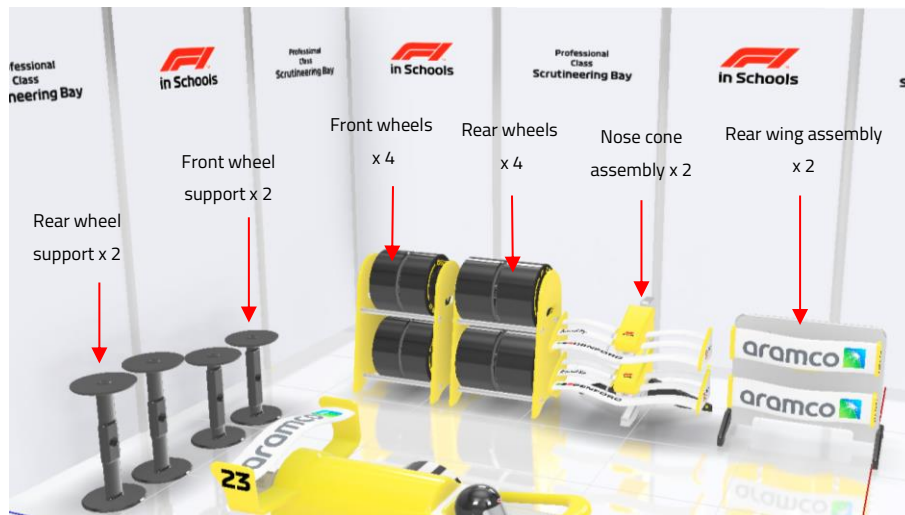

T3.9.1 Submitted components - [GENERAL]

Only submitted replacement components that are determined by the judges to be identical in design and geometry to those fitted to the cars will be allowed to be used during track repairs or post-race servicing.

T3.9.2 Introduced components - [GENERAL | Penalty - 5pts per component]

If any other items need to be introduced for car repairs a **5pt penalty** will be incurred per component item.

ARTICLE T4 - BODY

T4.1 Body construction - [GENERAL | Penalty - 20pts]

A single continuous piece of CNC manufactured F1® Model Block material must exist rear of the reference plane A, encompassing both the virtual cargo and power unit cartridge chamber.

T4.2 Virtual cargo - [PERFORMANCE | Penalty - 25pts]

A virtual cargo must be completely encompassed by the body and be wholly positioned between the front and rear wheel centre lines. The virtual cargo must have minimum dimensions as shown below, with its top surface located symmetrically about and positioned normal (90 degrees) to the vertical reference plane. The virtual cargo may also share common faces with the car body. All dimensions shown are absolute minimum.

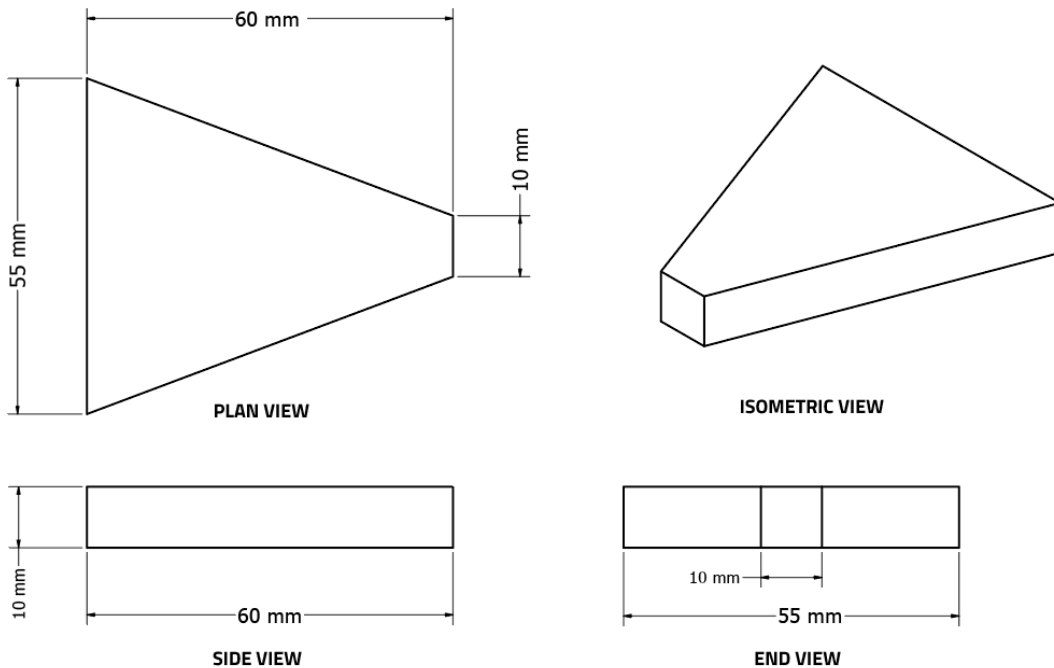

T4.3 Virtual cargo identification - [GENERAL | Penalty - 5 pts]

The virtual cargo location and compliance MUST be clearly dimensioned and identified by hatching, shading or block colour within the engineering drawings submitted for scrutineering. Please refer to the example diagram below, showing the virtual cargo clearly highlighted in red:

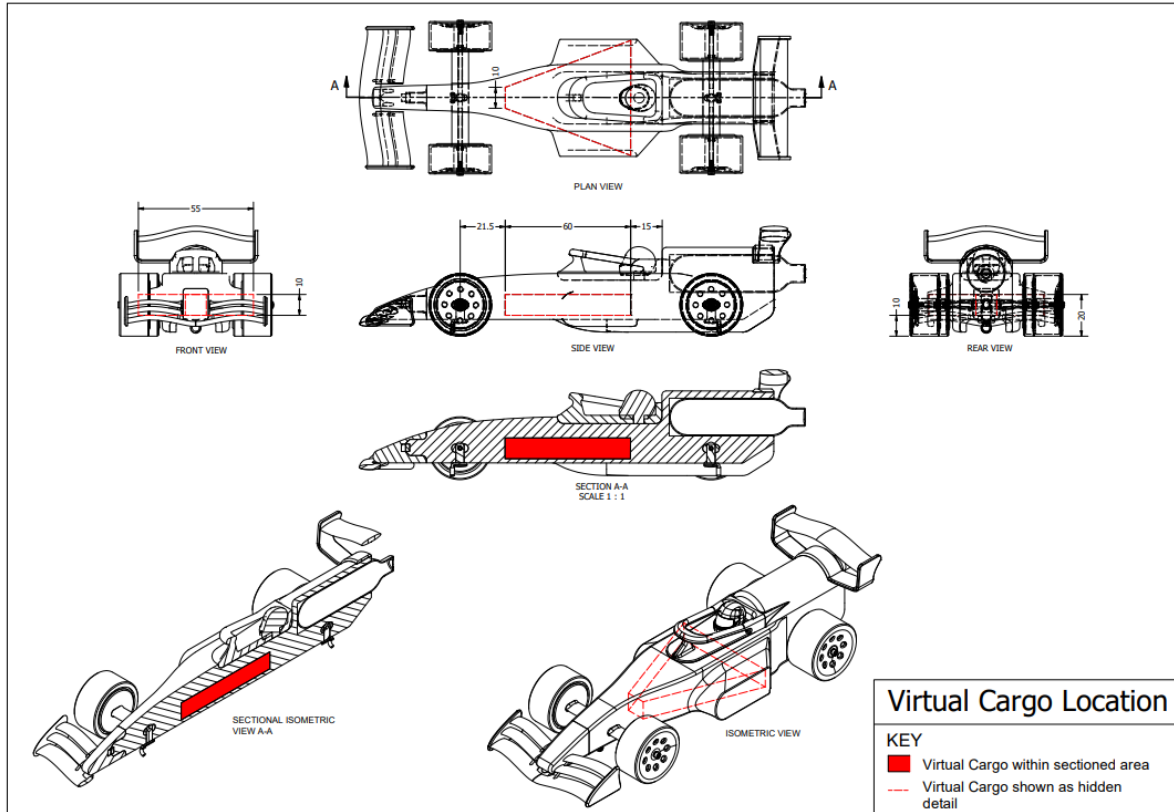

T4.4 Halo

T4.4.1 Halo visibility- [GENERAL | Penalty - 10 pts]

The Halo (refer ARTICLE T1.21) MUST be included in the car design without any dimensional changes. Visibility of the Halo circular notch must not be physically obstructed by any other component when viewed in the front or side views. The Halo must not be physically obstructed in the plan view except by the helmet. The file can be download from <http://www.f1inschools.com/downloads> Please see appendix ix for detailed dimensions.



T4.4.2 Halo circular notch height- [SAFETY | Penalty - 5pts]

To be effective the centre of the Circular Notch must be 34.0mm (± 1.0 mm) above the track surface. *To achieve this the bottom of the halo pocket must be 24.0mm above the track in the assembled car.*

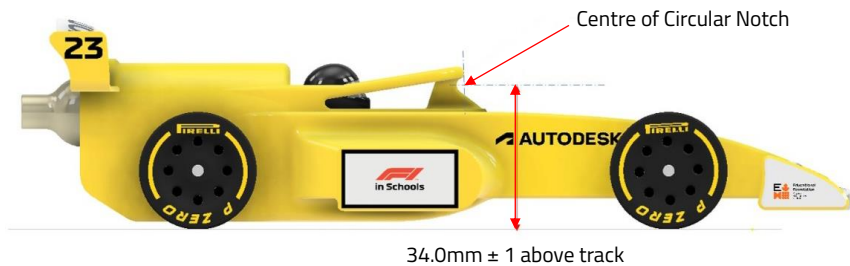
**T4.4.3 Halo Safety Test- [SAFETY | Penalty - 5pts]**

With the car supported on a power unit cartridge a 1kg load will be suspended to give a loading of 2kg (to be reviewed) at point of contact on the Halo circular notch.

**T4.5 Helmet - [GENERAL | Penalty - 5pts]**

The Helmet is a standard part designed by F1 in Schools that **MUST** be included in the car design without any dimensional changes. The Helmet is available to download as a universal 3D part from the F1 in Schools website. For this part and more free downloads, please visit <https://www.f1inschools.com/downloads.html>

The helmet may be manufactured out of any material.



T4.6 F1® in Schools logo decal location - [GENERAL | Penalty - 5pts]

An F1 in Schools logo decal (refer ARTICLE T1.12) must be wholly adhered to each side of the car, and be 100% visible in the respective side view. Teams may manufacture their own decals but must use the artwork supplied by F1 in Schools.



T4.7 Team Number - [GENERAL | Penalty - 2pts]

After registering for the World Finals event each team shall be issued with their official team number. This must be displayed on the car body between the front edge of the **halo** and reference plane A. The number should be clearly visible in the plan view and a minimum text height of **4mm**. If a team submits their car without the team number, then one will be provided at the world finals event.

Teams may additionally include the team number elsewhere on the car.

Minimum text height: 4.0mm



Min text height 4.0mm

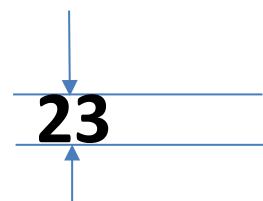

T4.8 Decal thickness - [GENERAL | Penalty - 5pts]

This is measured as the total thickness of any decal, excluding any surface finishes.

Absolute Max: 0.5mm

ARTICLE 5 - POWER UNIT CARTRIDGE CHAMBER

T5.1 Diameter - [SAFETY | Penalty - 5pts]

This is the diameter of the power unit cartridge chamber, measured at any point through its minimum depth.

Absolute Min: 18.0mm / Absolute Max: 18.5mm

T5.2 Distance from track surface - [GENERAL | Penalty - 5pts per millimetre]



This is measured with a full 8g power unit cartridge inserted into the cartridge chamber, from the rear centre of the power unit cartridge to the track surface, measured normal to the track surface. This is measured with a full 8g power unit cartridge inserted into the cartridge chamber with the car sitting on all four (4) wheels with no outside assistance.

Absolute Min: 30.0mm / Absolute Max: 40.0mm

T5.2: Distance
from track
surface

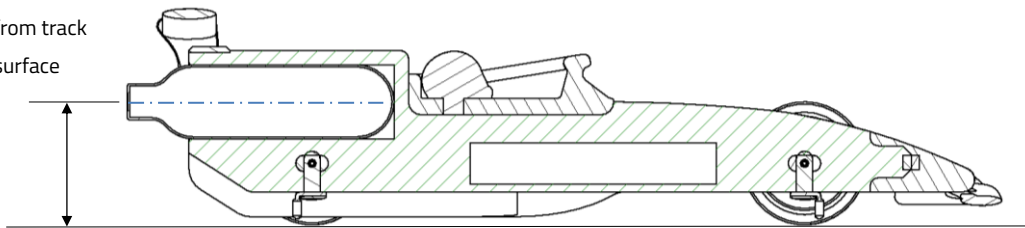

T5.3 Depth - [SAFETY | Penalty - 5pts]

The depth of the chamber is measured parallel to the vertical reference plane anywhere around the chamber circumference from the opening to the chamber end.

Absolute Min: 45.0mm / Absolute Max: 58.0mm

T5.4 Max angle of chamber - [SAFETY | Penalty - 5pts]

The absolute maximum angle of the chamber, parallel to the track surface. This is measured with a full 8g power unit cartridge inserted into the cartridge chamber with the car sitting on all four (4) wheels with no outside assistance.

Absolute Min: -3° Absolute Max: 3°

T5.5 Chamber safety zone - [SAFETY | Penalty - 10pts]

A safety zone of F1® Model Block material with a minimum thickness of 3.0mm must be maintained around the minimum chamber volume. The chamber safety zone and connection to the car body will be assessed and if determined below the minimum thickness, may be considered a safety issue at the judge's discretion, see ARTICLE T3.2.

IMPORTANT: the entire circumference and depth of the power unit cartridge chamber must not be intersected by any object.

Absolute Min: 3.0mm

T5.5 Chamber
safety zone

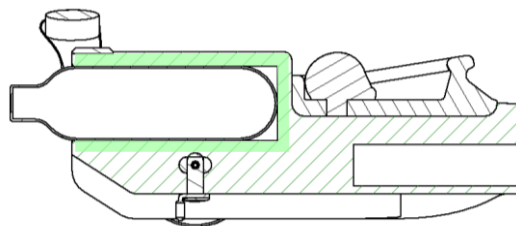

(Cartridge chamber should be free of any paint)

T5.6 Power unit cartridge visibility - [PERFORMANCE | Penalty - 10pts per millimetre]



When fully inserted, the power unit cartridge must protrude a minimum of 5.0mm from the rear of the car and be visible in it's entirety when viewed radially around the longitudinal centreline of the power unit cartridge.

Absolute Min: 5.0mm

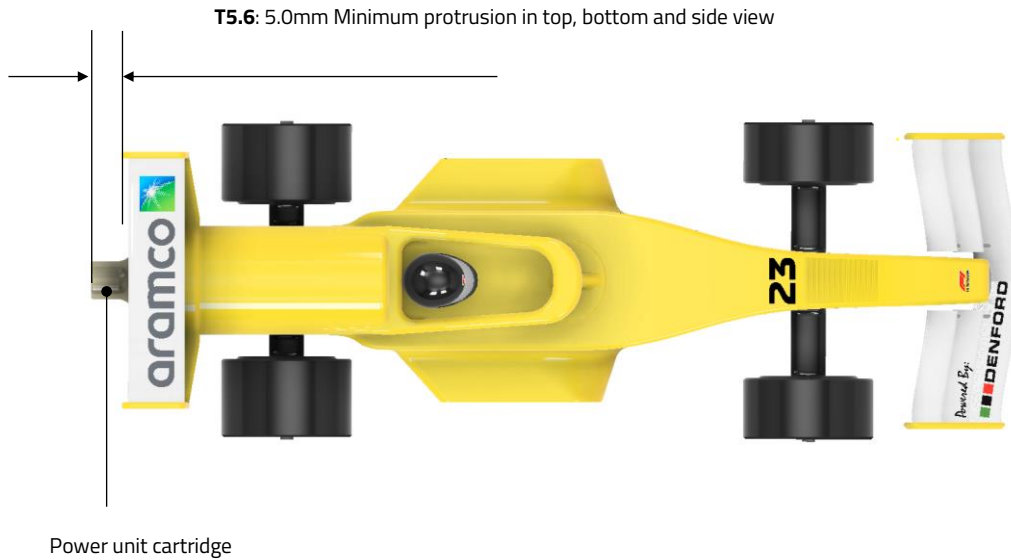

ARTICLE T6 - TETHER LINE GUIDES

T6.1 Location - [SAFETY | Penalty - 10pts]

Each car must have only two (2) firmly secured tether line guides, one on or up to 10.0mm in front of the front axle centre line and one on or up to 10.0mm behind the rear axle centre line of the car. The track tether line must **only** pass through the two tether line guides during racing.

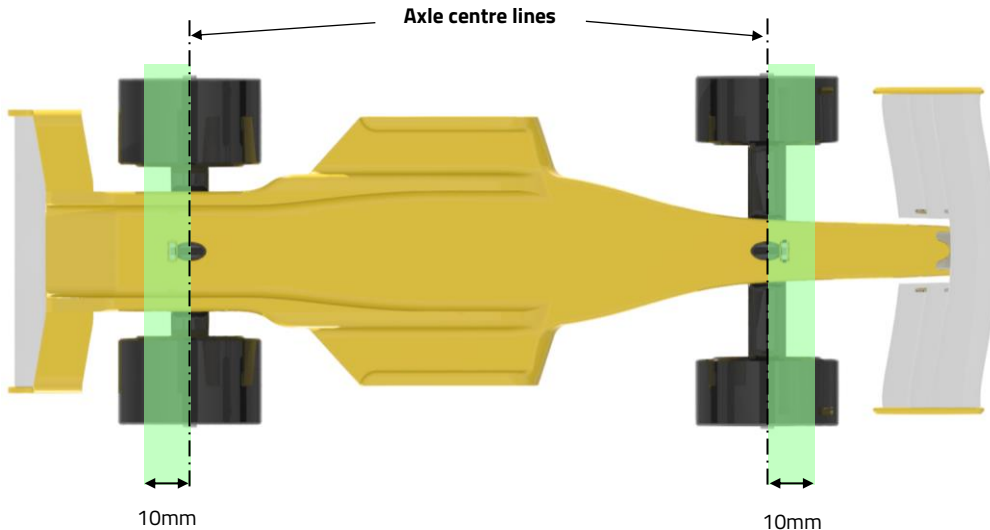

T6.2 Internal dimension - [SAFETY | Penalty - 5pts]

This is the minimum and maximum internal measurement of the opening within the guide, which the tether line passes through. This will be measured using a 3.5mm and/or 6.0mm diameter tool.

Absolute Min: 3.5mm / Absolute Max: 6.0mm

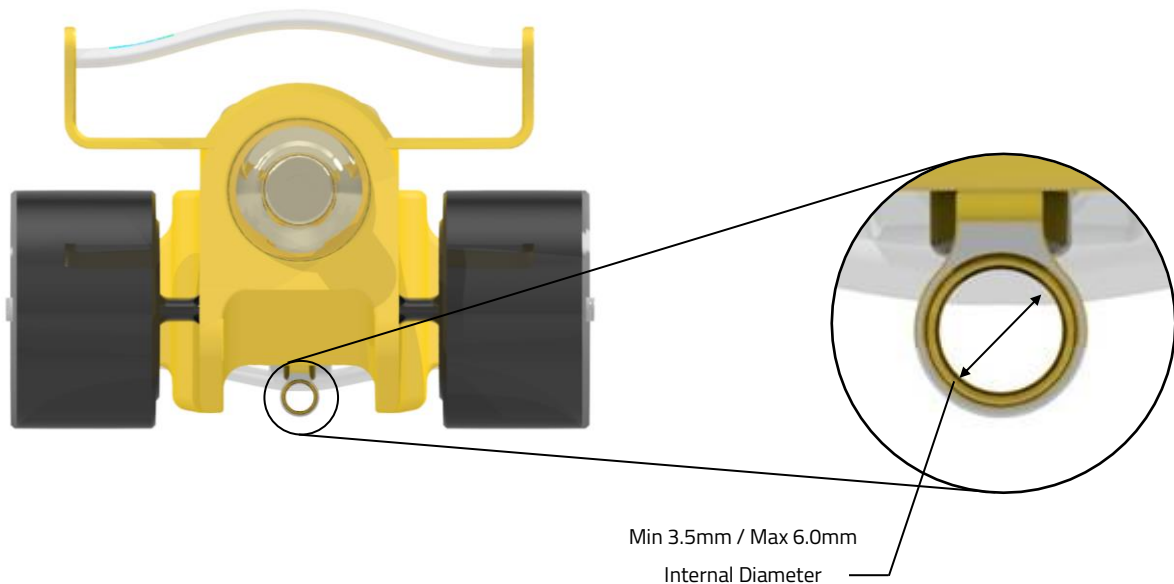

T6.3 Tether line guide safety - [SAFETY | Penalty - 10pts]

The guide holes must be completely closed to prevent the tether line from slipping out during racing. The construction of the tether line guides will be closely examined in relation to safety, please refer to ARTICLE T3.2 for more information. The guides must be robust so as to prevent the diameter or shape changing during racing. The below tether line guide test will be conducted during scrutineering. A 200g weight will be suspended from each tether line guide to check the guides are securely fitted to the car and safe to race.



ARTICLE T7 - WHEELS AND WHEEL SUPPORT STRUCTURES

T7.1 Number and location - [GENERAL | Penalty - 25pts]

The car assembly must include four (4) cylindrical wheels, a maximum of two (2) at the front and a maximum of two (2) at the rear. Opposing wheels must share a common centre line / axis.

T7.2 Distance between opposing wheels - [PERFORMANCE | Penalty - 2.5pts per millimetre per axle]

This is measured as the innermost distance of the rotating wheel components (other than a rotating axle) between the two (2) opposing wheels measured parallel to the track surface.

T7.2.1 Front Axle - Absolute Min: 38.0 mm

T7.2.2 Rear Axle - Absolute Min: 30.0 mm

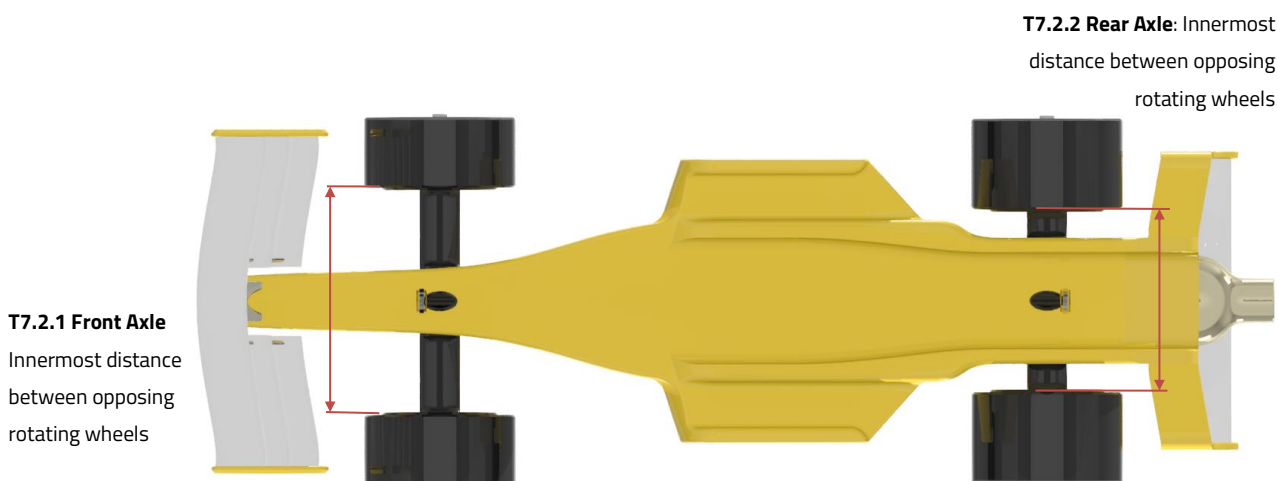

T7.3 Wheelbase - [PERFORMANCE | Penalty -5pts per millimetre]

The wheelbase of the vehicle is the distance between the centre line of the front and rear wheels as viewed in the side view.

Absolute Min: 120.0mm / Absolute Max: 140.0mm



T7.4 Track contact width - [PERFORMANCE | Penalty - 2.5pts per millimetre per wheel]



This is measured along the surface of the wheel that makes constant contact with the track surface, excluding any chamfers or fillets.

T7.4.1 Front wheels - Absolute Min: 13.0mm

T7.4.2 Rear wheels - Absolute Min: 17.0mm

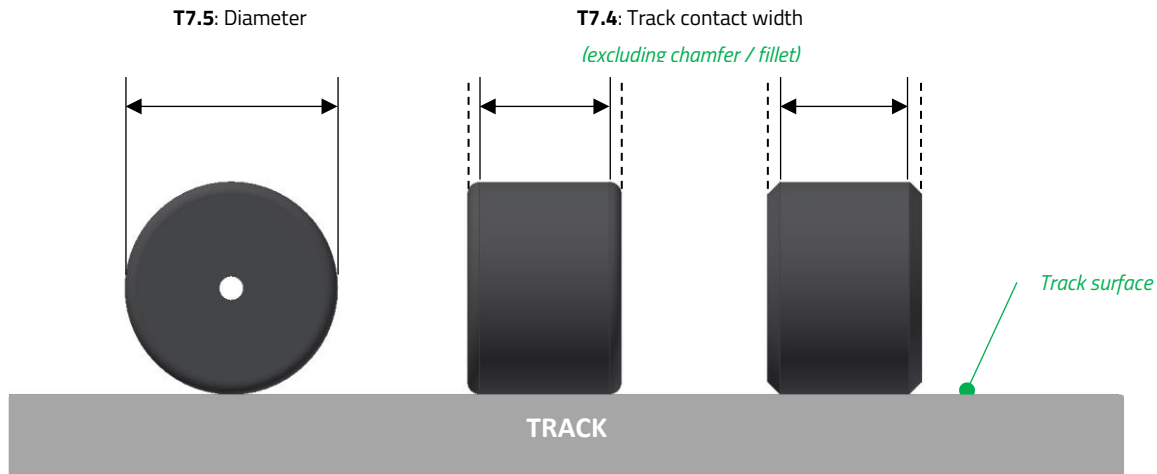

T7.5 Diameter - [PERFORMANCE | Penalty - 2.5pts per millimetre per wheel]



This is the wheel diameter measured across the minimum track contact width rolling surface.

Absolute Min: 28.0mm / Absolute Max: 32.0mm

T7.6 Race track contact - [PERFORMANCE | Penalty - 2.5pts per wheel]

All four (4) wheels must touch the racing surface at the same time across the full track contact width, measured with a full power unit cartridge inserted with the car sitting on all four (4) wheels with no outside assistance. Race track contact must be maintained prior to car launch and during racing.

T7.7 Rolling surface - [PERFORMANCE | Penalty - 2.5pts per wheel]

The wheel diameter must be consistent across the track contact width. *(i.e. no tread like features are permitted)*

T7.8 Rotation - [PERFORMANCE | Penalty - 5pts per wheel]

All four (4) wheels must rotate freely about their own centre axis to facilitate forward motion of the car during racing. The specification judge must be able to validate this with reasonably minimal effort, using a 2° incline test during scrutineering.

Absolute Max: 2°

T7.9 Visibility in top and bottom views - [PERFORMANCE]

The visibility of all wheels must not be physically obscured by any component of the car in the car’s top and bottom elevation views. Car body or any other components must not exist within the dimensions illustrated below. These dimensions must exist from the inside edges of each wheels’ track contact width to the extreme width of the car assembly and a height from track surface of 65.0mm. This is measured, parallel to the vertical reference plane and track surface. *Please also refer to T8.6 and T9.6 – Clear Airflow.*

Regulation	Location	Dimension	Penalty
T7.9.1	In front of front wheels	Absolute Min: 5.0mm	2.5pts
T7.9.2	Behind front wheels	Absolute Min: 15.0mm	5pts
T7.9.3	In front of rear wheels	Absolute minimum dimensions on diagram below	5pts
T7.9.4	Behind rear wheels	Absolute Min: 5.0mm	2.5pts

Scrutineering tools used to define these clearances will be manufactured to dimensions as illustrated below.

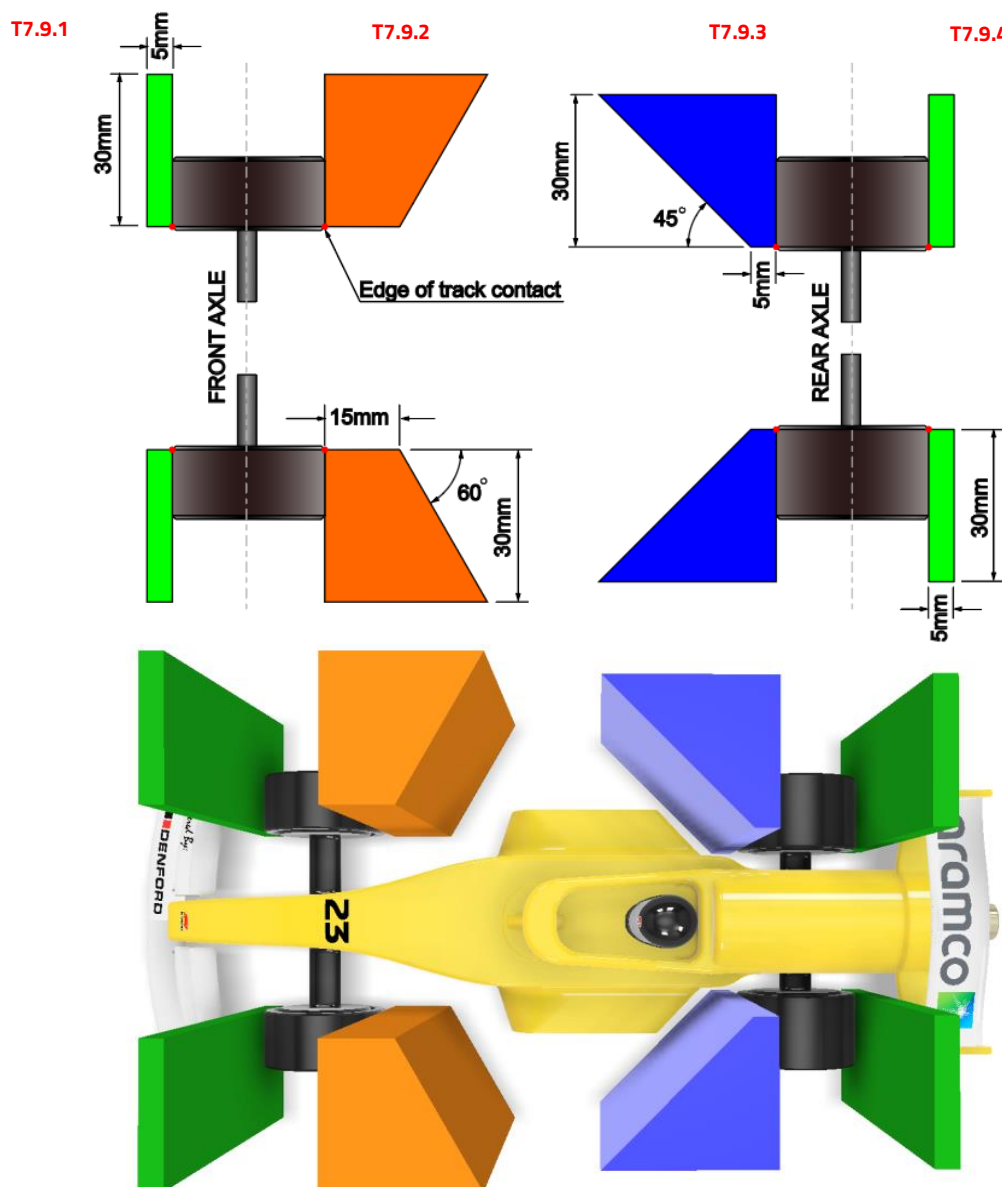

T7.10 Visibility in side views - [PERFORMANCE | Penalty - 10pts per wheel]

The visibility of all wheels must not be physically obscured by any component of the car with the exception of any wheel support systems, in the car’s side elevation views.



External wheel support systems such as hubcaps

T7.11 Visibility in front view - [PERFORMANCE | Penalty - 10pts per millimetre]



The visibility of the front wheels in the car’s front view may only be physically obstructed to a height of 20.0mm from the track surface. This is measured with a full 8g power unit cartridge inserted into the cartridge chamber with the car sitting on all four (4) wheels with no outside assistance.

Absolute Max: 20mm

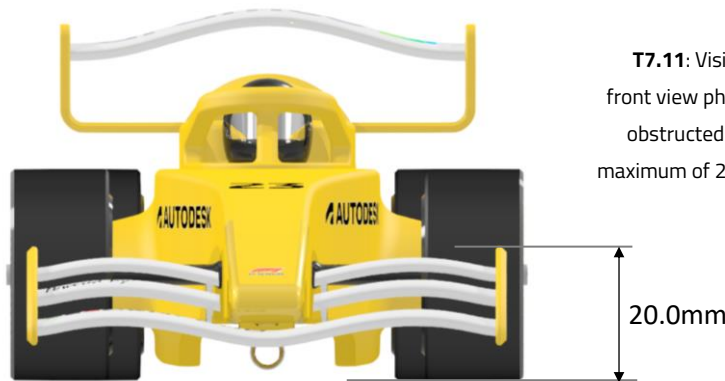

T7.11: Visibility in front view physically obstructed up to a maximum of 20.0mm

T7.12 Wheel support - [GENERAL | Penalty - 5pts each]

T7.12.1 Wheel support systems: Wheel support systems may only exist within the cylindrical volume generated through the diameter of the two (2) opposing wheels. *Refer to ARTICLE T3.8 Track clearance.*

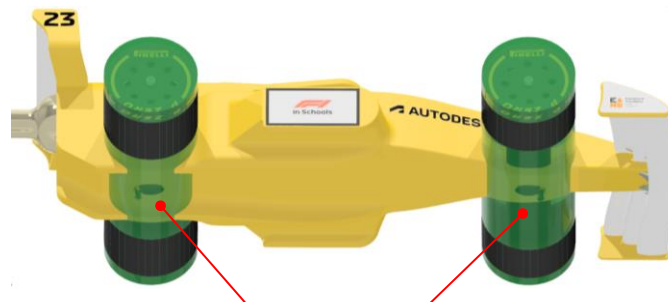

Cylindrical Volume generated through opposing wheels.

T7.12.2 Wheel support systems identification: The surfaces defining the wheel support structures MUST be dimensioned and identified clearly by hatching, shading or block colour within the engineering drawings submitted for scrutineering. *(Construction lines are acceptable to define the boundaries between components such as nose cone and wing support structures.) Also refer to the definition in ARTICLE T1.15 for guidance on annotating these features in your Engineering Drawings.*

T7.13 Wheel safety test [SAFETY | Penalty - 2.5pts per wheel]

To prevent wheel detachment during racing and encourage good engineering practice a wheel safety test will be carried out.

The wheels must be robust so as to prevent the diameter or shape changing during racing. The below wheel test will be conducted during scrutineering. A 100g weight will be suspended from each wheel.

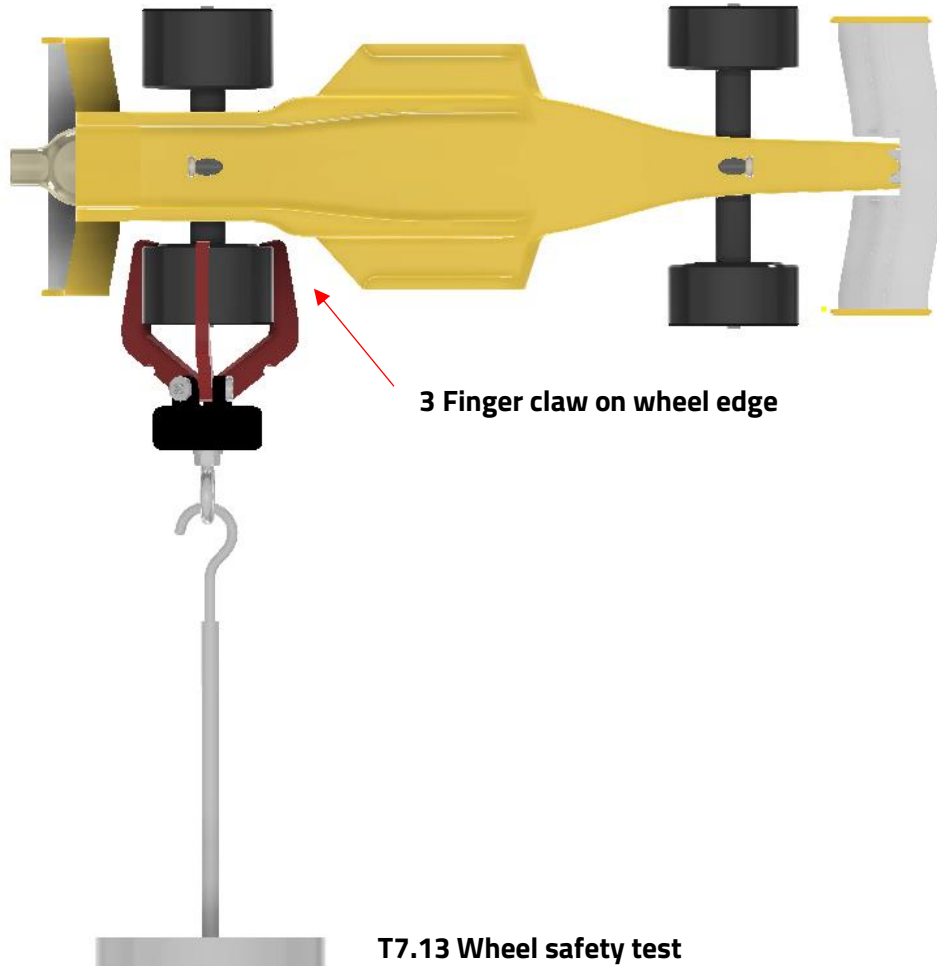

ARTICLE T8 - NOSE, FRONT WING AND WING SUPPORT STRUCTURES

T8.1 Nose, front wing and wing support structure identification - [GENERAL | Penalty - 5pts]

The surfaces defining the nose, front wing(s) and wing support structures **must** be dimensioned and identified clearly by hatching, shading or block colour within the engineering drawings submitted for scrutineering. *(Clearly labelled construction lines are acceptable to define the boundaries between components such as nose cone and wing support structure). Also refer to the definition in ARTICLE T1.15 for guidance on annotating these features in your Engineering Drawings.*

T8.2 Nose cone assembly dimension - [GENERAL | Penalty - 5pts each]

This is measured in front of and parallel to reference plane A to the extreme front of the fully assembled car. From the Reference plane A the nose cone overhang is 30mm minimum and 40mm maximum.

Absolute Min: 30.0mm / Absolute Max: 40.0mm



T8.3 Front wing(s) description and placement - [General | Penalty - 5pts]

The design of the car should resemble an actual F1 car through the inclusion of a wing(s) on the nose of the car and a wing at the rear of the car. Each wing section must have a leading edge and a trailing edge across its full span. *Refer to the definition in ARTICLE T1.5.*

T8.4 Front wing(s) construction and rigidity - [General - Penalty - 5pts]

The nose, front wing(s) and any support structures may be manufactured from any separate materials. The wing span dimension must remain unchanged during races *(i.e. wings must be rigid, ruled at the judge's discretion).*

T8.5 Front wing and wing support structure location - [General - Penalty - 10pts]

The whole of the front wing(s) and any support structure and nose cone **must** be in front of reference plane A and no more than 25.0mm above the track surface when viewed in the side elevation.

Absolute Max height: 25.0mm

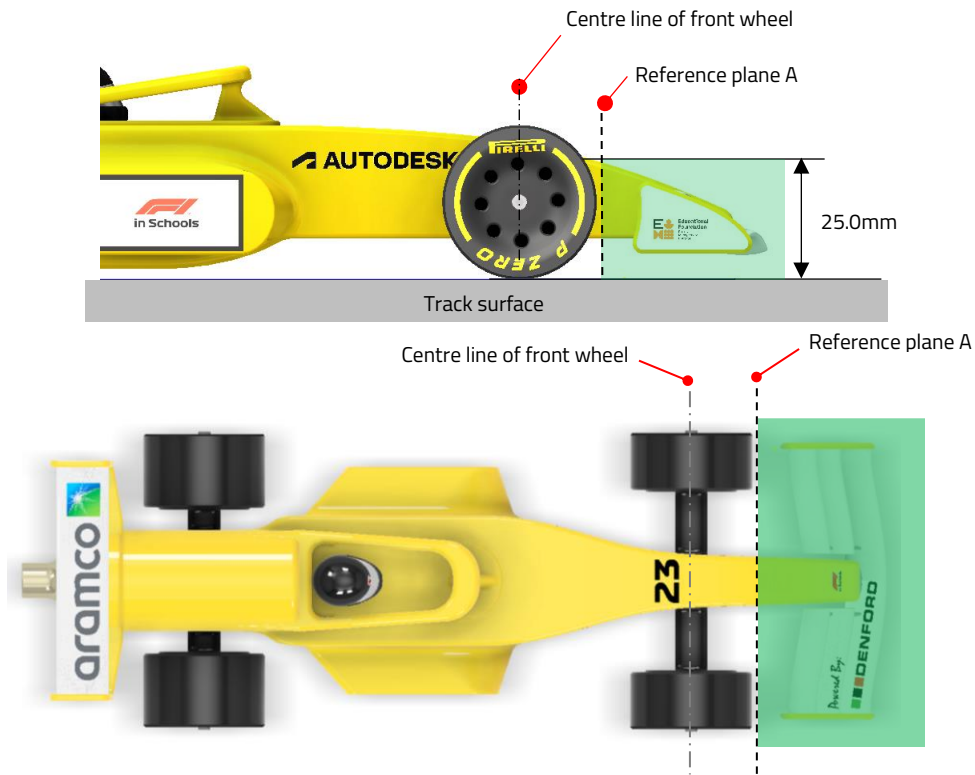

T8.5: Front wing and wing support structure location, shown highlighted green.

T8.6 Front Wing Dimensions - [PERFORMANCE]

PP+ T8.6.1 Front wing span - [PERFORMANCE | Penalty - 2pts per millimetre]

The front wing span will be measured at right angles to the vertical reference plane along the leading edge, trailing edge, top surface and bottom surface of the wing, whichever is shortest will be considered as the maximum span. Where the front wing span is intersected by another part of the car, the total span is the sum of a maximum of two (2) wing segments, which **must** be no less than 25.0mm each. *(See illustration below)*

Absolute Min: 25.0mm x 2 = 50.0mm or 50.0mm x 1 = 50.0mm

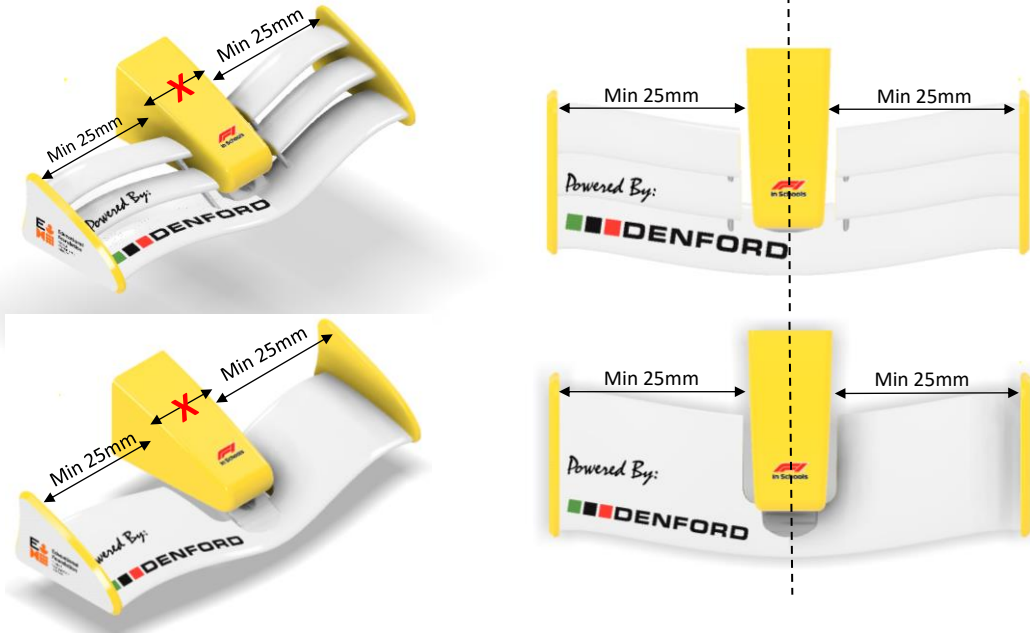

PP+ **T8.6.2 Front wing chord - [PERFORMANCE | Penalty - 1pt per millimetre]**

The front wing chord minimum to maximum dimensions must exist throughout the existing wing span. The chord is the distance between the leading edge and trailing edge of up to three elements that must overlap, it will be measured parallel to the vertical reference plane and normal to the track surface. Front wing chord compliancy does not depend on span. Multi vane wings must overlap. *(See illustration below and appendix v)*

Absolute Min: 15.0mm / Absolute Max: 25.0mm

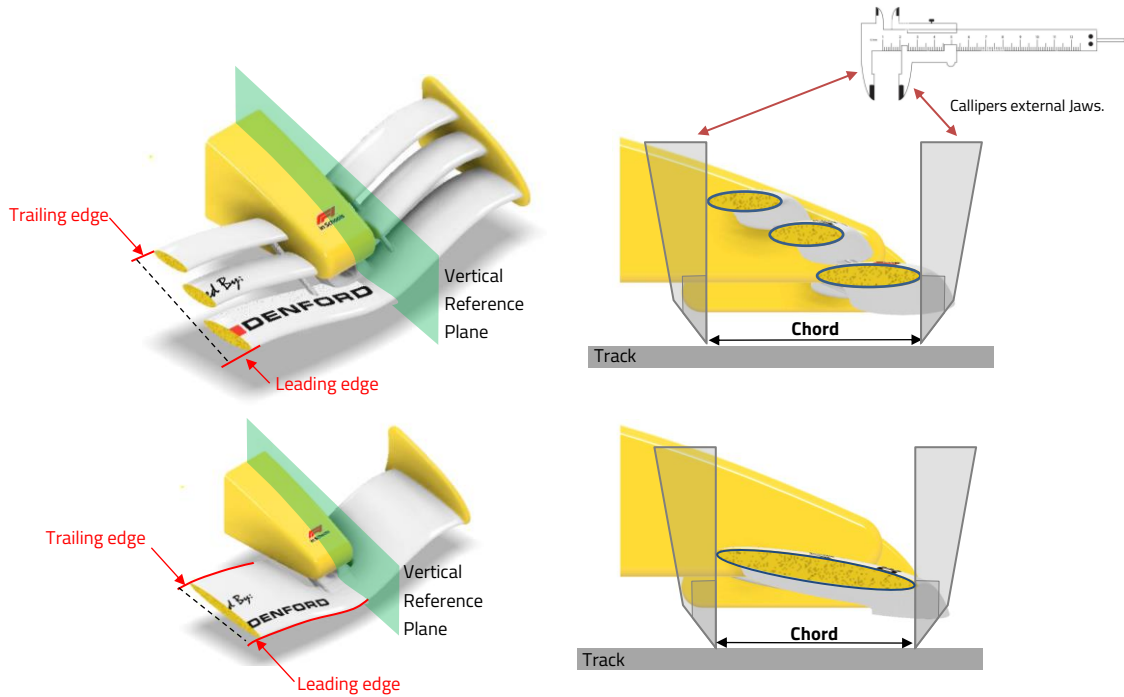

PP+ **T8.6.3 Front wing thickness - [PERFORMANCE | Penalty - 1pt per millimetre]**

The wing thickness minimum to maximum dimensions **must** exist throughout the wing's existing span and at a point along the existing chord. Front wing thickness compliancy does not depend on span and / or chord.

(See illustration below)

Absolute Min: 2.0mm / Absolute Max: 6.0mm



T8.7 Front wing clear airflow - [PERFORMANCE | Penalty - 5pts]

The front wing(s), measured across its / their minimum existing span, must have a minimum of 5.0mm of clear 'air' space to any other part of the car or track surface, measured normal from any part of the wings surface.

Absolute Min: 5.0mm

(To allow for fillet rads where a wing joins a support structure this will be checked with a 5.0mm diameter spherical ball on the end of a 2mm diameter rod.)



Single Vane

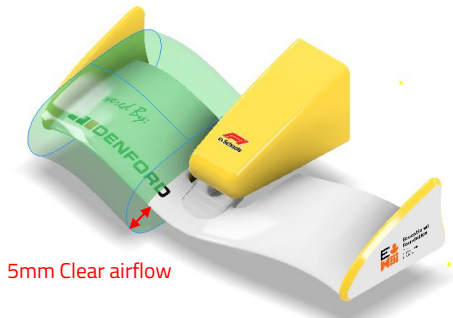

Multi Vane

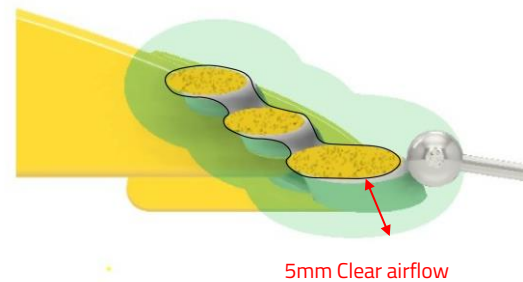
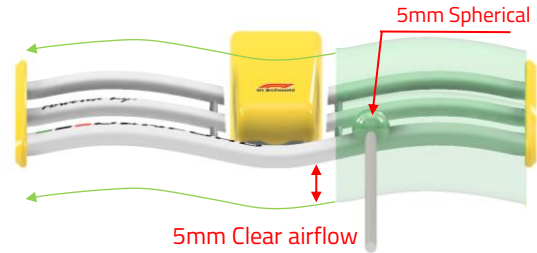
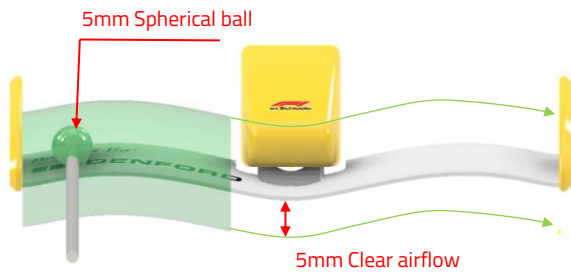
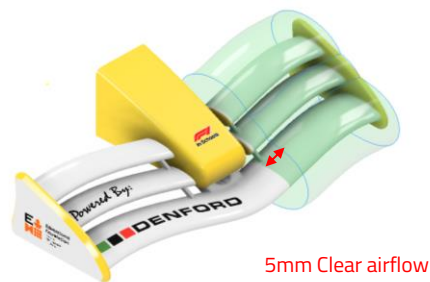

T8.8 Front wing visibility - [PERFORMANCE | Penalty - 10pts]

Visibility of the front wing(s) must not be physically obstructed by any other component when viewed in the front view.



Visibility of front wing not physically obstructed in front view.

T8.9 Nose cone replacement challenge (optional) [GENERAL]

The replaceable nose cone assembly challenge is an optional challenge and consists of a team being able to completely remove and replace the car’s nose cone assembly in under 60 seconds. This will need to be demonstrated on one of the two cars and recorded during car submission. The fastest nose changes will be nominated for the Fastest Nose Change Award. More information shall be included in the 2023 Competition Regulations.

Maximum time to change the nose cone assembly – 60 seconds.



Example nose cone

ARTICLE T9 - Rear wing and wing support structures.

T9.1 Rear wing and wing support structure identification - [General - Penalty - 5pts]

The surfaces defining the rear wing and wing support structure(s) **must** be dimensioned and identified clearly by hatching, shading or block colour within the engineering drawings submitted for scrutineering. *(Clearly labeled construction lines are acceptable to define the boundaries between components such as car body and wheel support structures). Also refer to the definition in ARTICLE T1.15 for guidance on annotating these features in your Engineering Drawings.*

T9.2 Rear wing description and placement - [General - Penalty - 5pts]

The design of an F1 in Schools car should resemble an actual F1 car through the inclusion of a wing at the rear of the car. To be considered a wing section it must have a leading edge and a trailing edge across its required span. *Refer to the definition in ARTICLE T1.5*

T9.3 Rear wing construction and rigidity - [General Penalty - 5pts]

The rear wing and any support structures may be manufactured from any separate materials. The wing span dimension must remain unchanged during races *(i.e. wings must be rigid, ruled at the judge's discretion).*

T9.4 Rear wing and wing support structure location - [General - Penalty - 10pts]

The whole of the rear wing and any support structure **must** be to the rear of reference plane B.

T9.4.1 Rear overhang length This is measured to the rear of and parallel to reference plane B to the extreme rear of the fully assembled car. From the Reference plane B the rear wing and wing support structure overhang is a minimum of 30.0mm and a maximum of 40.0mm.

Absolute Min: 30.0mm / Absolute Max: 40.0mm

T9.4.2 Rear overhang height This is measured to the rear of reference plane B to the highest point of the fully assembled car from the track surface.

Absolute Max: 65.0mm

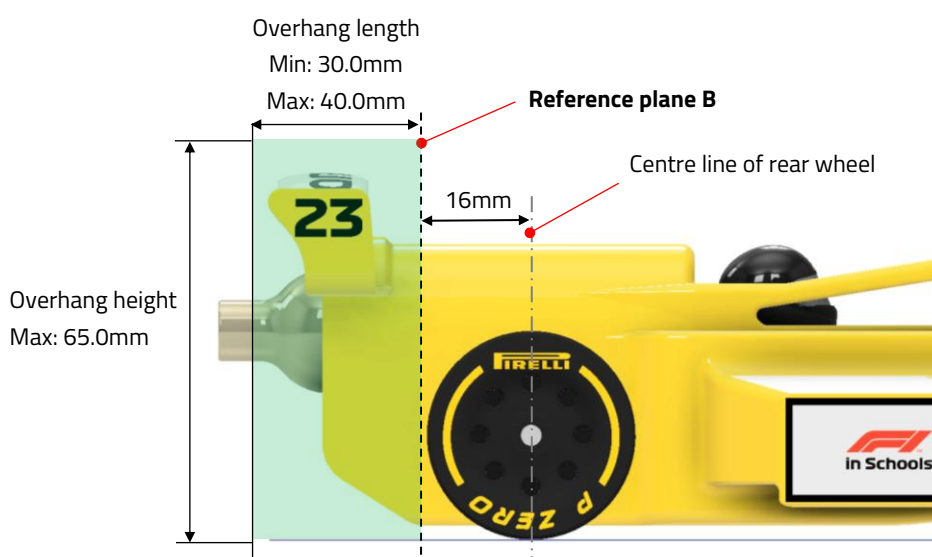

T9.5 Rear wing dimensions - [PERFORMANCE]

PP+ T9.5.1 Rear wing span - [PERFORMANCE | Penalty - 2pts per millimetre]

The rear wing span will be measured at right angles to the vertical reference plane along the leading edge, trailing edge, top surface and bottom surface of the wing, whichever is shortest will be considered as the maximum span. The rear wing **must** exist as a single, unbroken minimum span of 50.0mm.

(See illustration below)

Absolute Min: 50.0mm

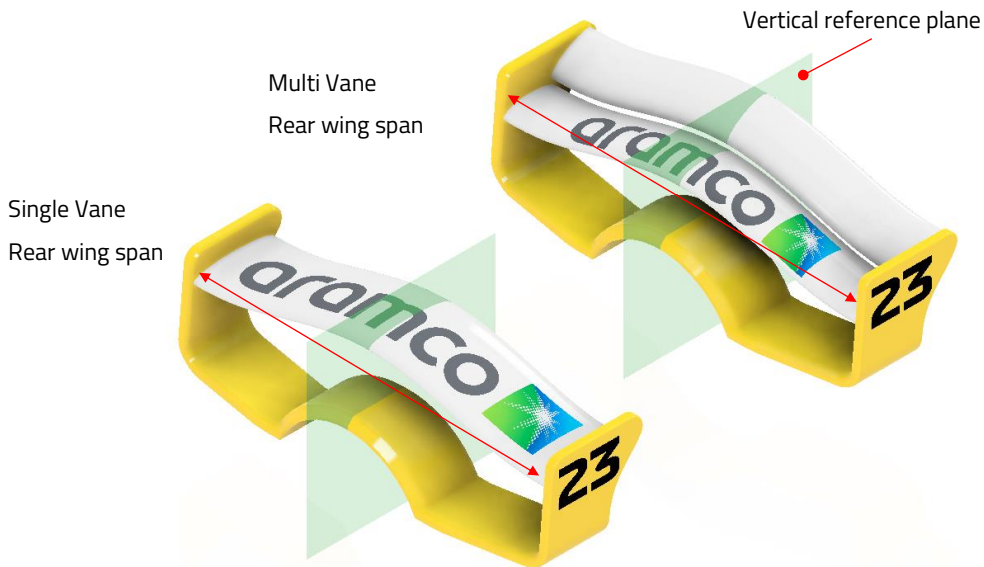

PP+ T9.5.2 Rear wing chord - [PERFORMANCE | Penalty - 1pt per millimetre]

The rear wing chord minimum to maximum dimensions **must** exist throughout its existing wing span. The chord is the distance between the leading edge and trailing edge of up to two elements that must overlap, it will be measured parallel to the vertical reference plane and normal to the track surface. Rear wing chord compliancy does not depend on span. Multi vane wings must overlap. *(See illustration below and appendix v)*

Absolute Min: 15.0mm / Absolute Max: 25.0mm

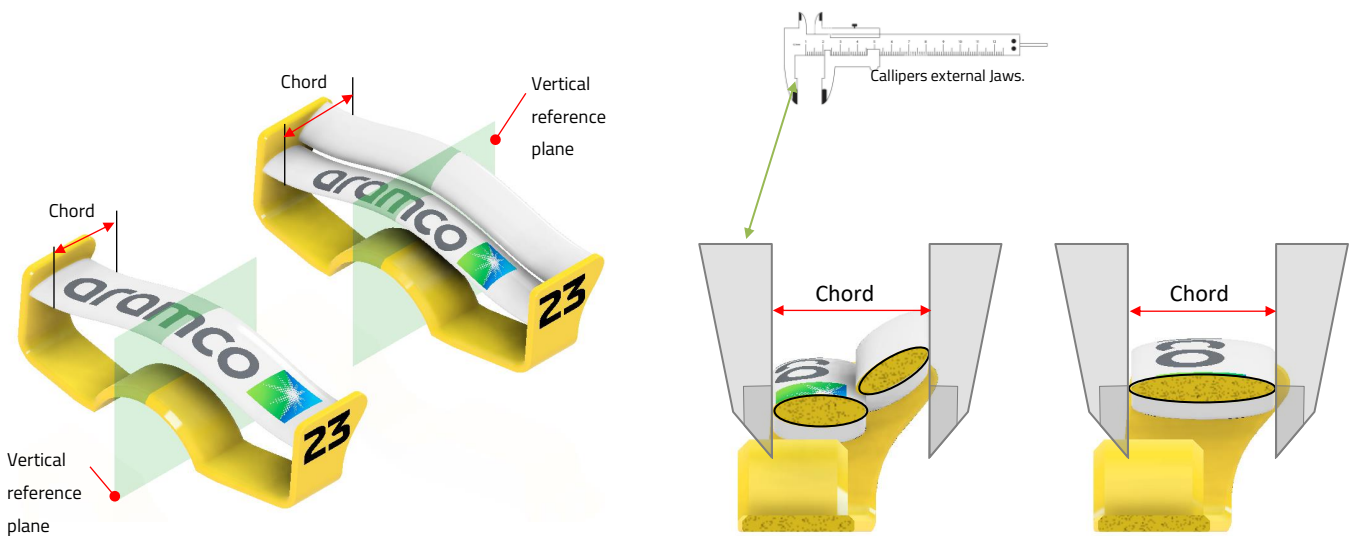



T9.5.3 Rear wing thickness - [PERFORMANCE | Penalty - 1pt per millimetre]

The wing thickness minimum to maximum dimensions **must** exist throughout the wing’s **existing** span and at a point along the existing chord. Rear wing thickness compliancy does not depend on span and / or chord.

(See illustration below)

Absolute Min: 2.0mm / Absolute Max: 6.0mm

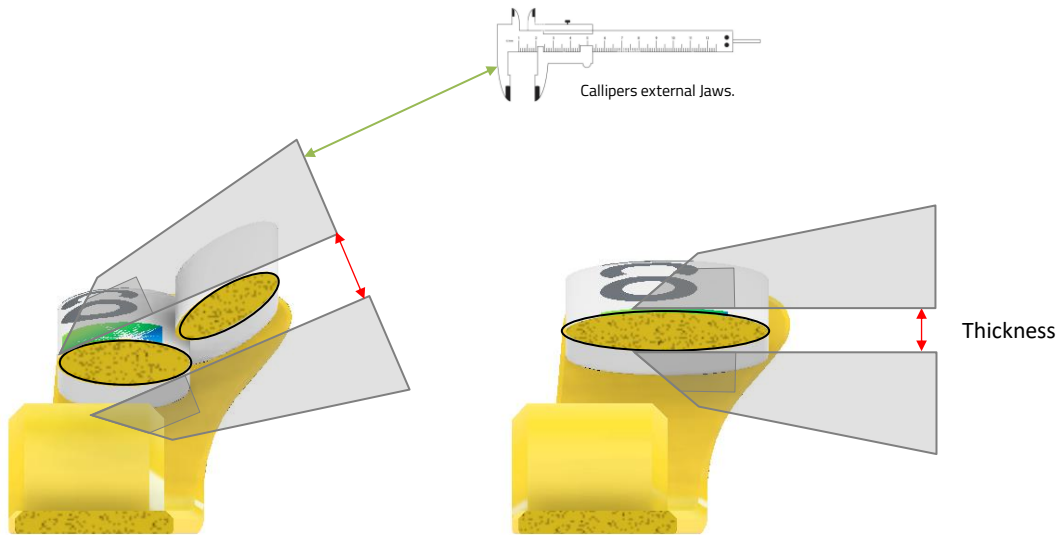

T9.5.4 Rear wing height deviation - [GENERAL | Penalty - 1pt per millimetre]

The maximum change in height deviation from the highest point of the wing is 15mm. Measured along the minimum span on the top surface.

Absolute maximum height deviation: 15.0mm

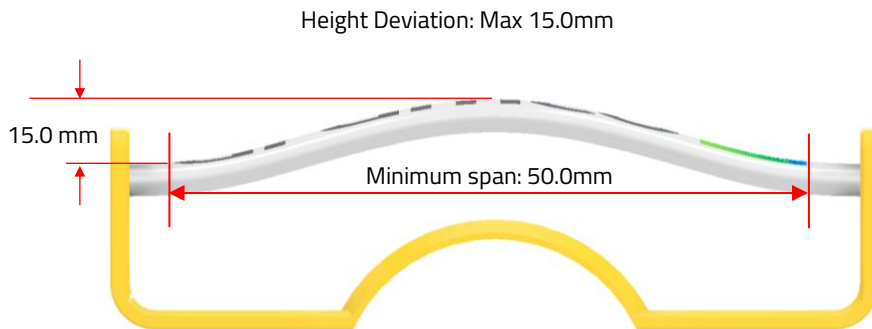

T9.6 Rear wing clear airflow - [PERFORMANCE | Penalty - 5pts]

The rear wing, measured across its existing span, must have a minimum of 5.0mm of clear 'air' space to any other part of the car or track surface, measured normal from any part of the wings surface.

Absolute Min: 5.0mm

(This will be checked with a 5.0mm diameter spherical ball on the end of a 2mm diameter rod.)

5.0mm diameter spherical ball →  ← 2mm diameter rod

Single Vane

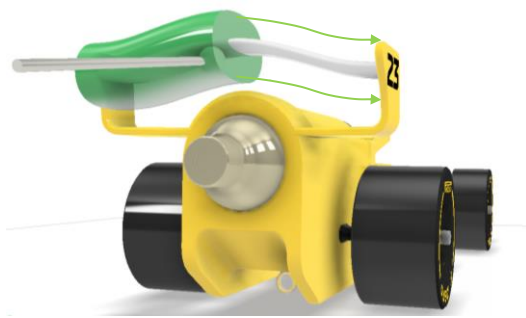

Double Vane

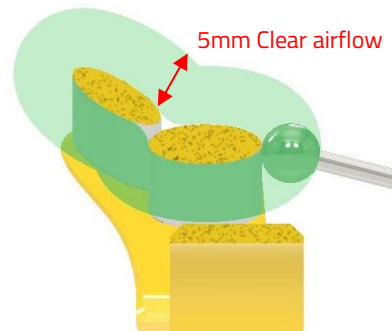
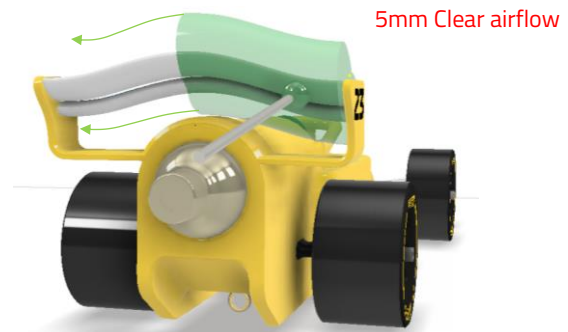

T9.7 Rear wing visibility - [PERFORMANCE | Penalty - 10pts]

Visibility of the rear wing must not be physically obstructed by any other component when viewed in the front view.

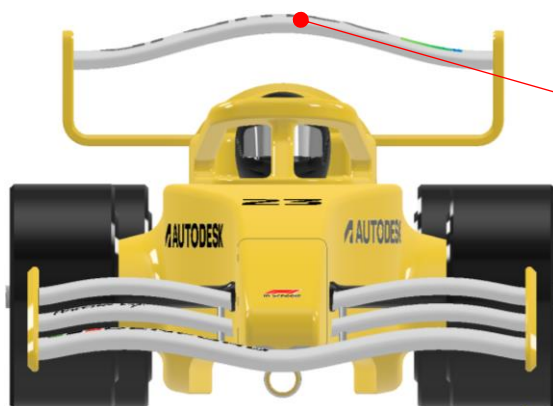

Visibility of rear wing not physically obstructed in front view

Illustrations for T8 and T9 below:

(See Appendix iii for more detail, examples and penalties relating to wing span, chord and thickness)

T9.5.1 Rear wing span

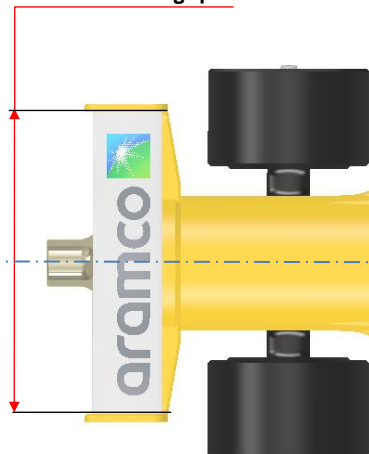

(Illustrated here as 1 x 50mm single span)

T8.5.1 Front wing span

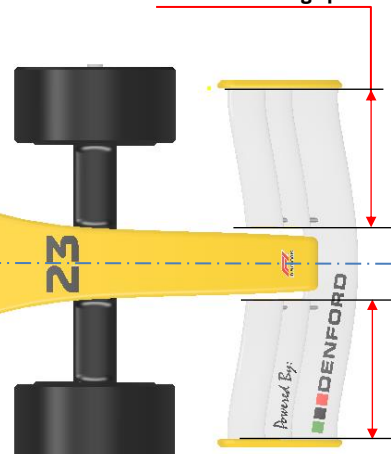

(Illustrated here as 2 x 25mm span segments)

ARTICLE T10 - Additional Components

T10.1 Description and placement [GENERAL]

Only the power unit cartridge, as positioned by race officials, is permitted to make contact with the launch pods and/or cars prior to and/or during racing. Any car alignment tools must be approved by race officials prior to use. Please refer also to the Aramco F1® in Schools World Finals 2023 Competition Regulations.

aramco
F1® in Schools
WORLD FINALS

APPENDIX

OTHER INFORMATION & ILLUSTRATIONS

Appendix i:	Start Box / Finish Gate	47
Appendix ii:	Official F1® Model Block dimensions	48
Appendix iii:	Front wing compliance examples	49
Appendix iv:	Rear wing compliance examples	51
Appendix v:	Wing overlap	53
Appendix vi:	Official Power Pack dimensions	54
Appendix vii:	Car Deceleration System	54
Appendix viii:	Component identification example	55
Appendix ix:	Halo	56



APPENDIX - OTHER INFORMATION & ILLUSTRATIONS

i. Start Box and Finish Gate

The start boxes are designed to sit centrally within each lane of the track.

The distance from the emitter centre line to the race track surface on both lanes is ~7mm.

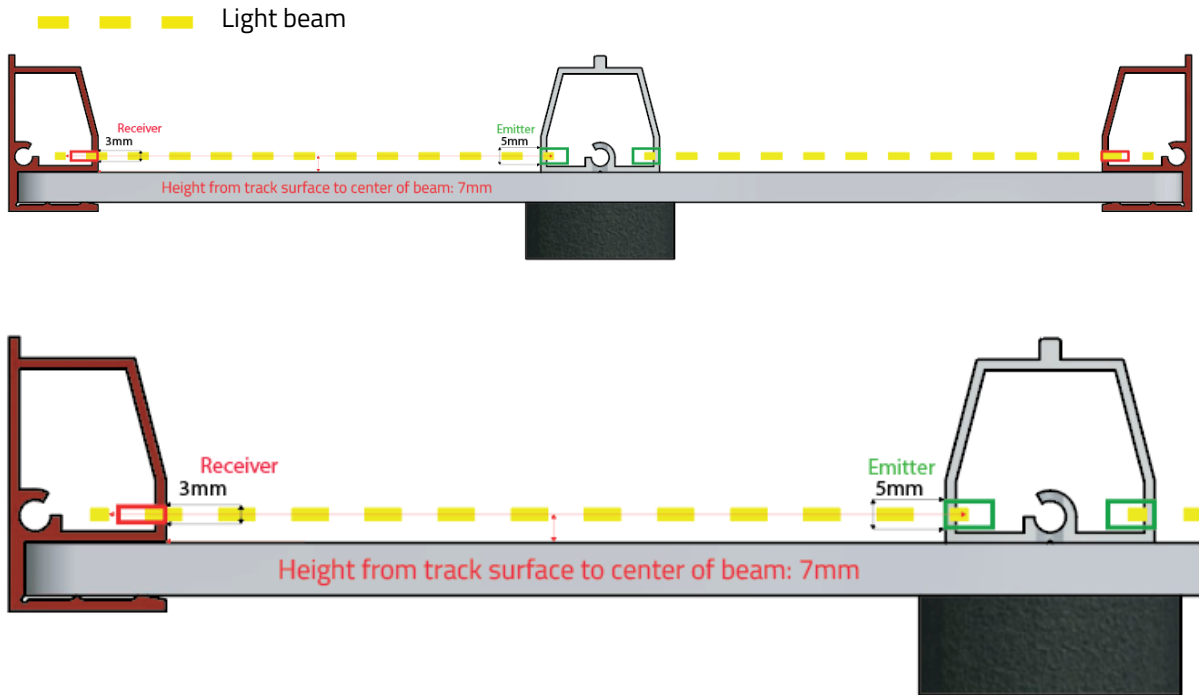

ii. Official F1® Model Block Dimensions

Below: orthographic projection of F1® Model Block. All dimensions shown in millimetres



This component is available to download as a universal 3D part from the F1 in Schools website. For this part and more free downloads, please visit

<https://www.f1inschools.com/downloads.html>

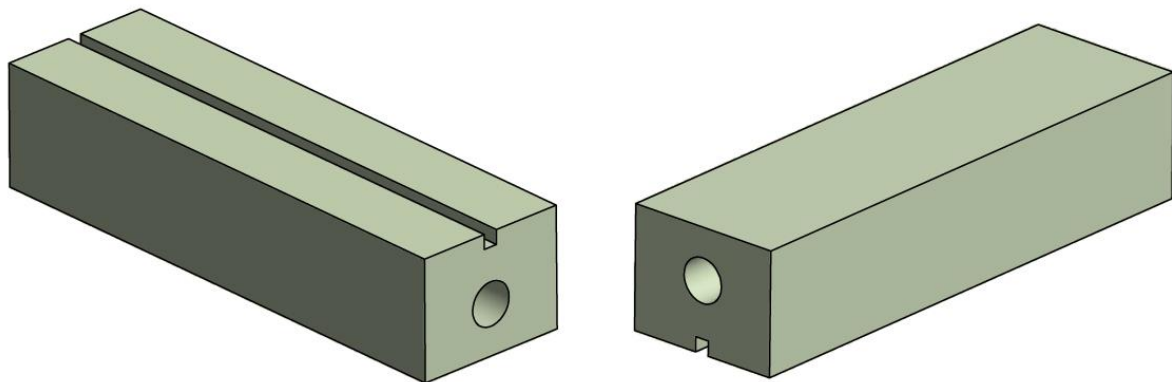
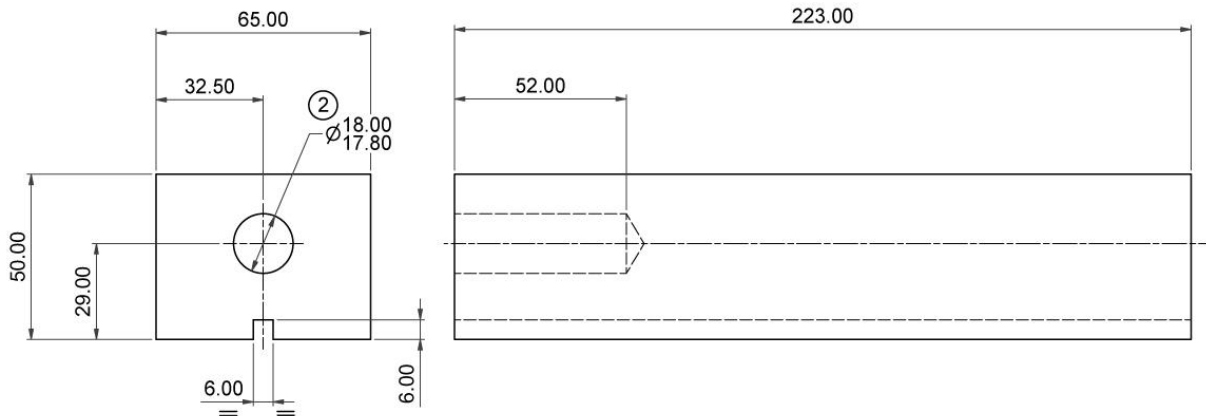

iii. Front wing compliance examples

The following table shows how penalty points are awarded for front wing span, chord or thickness dimensions that do not meet the specifications set out in **T8.5.1**, **T8.5.2** and **T8.5.3**.

This is not an exhaustive list of all possible wing configurations.

Front Wing Examples – Single Vane	T8.5.1 Span -2pts per mm	T8.5.2 Chord -1pts per mm	T8.5.3 Thickness -1pts per mm	Remarks
	PASS	PASS	PASS	<p>Wing span is split by single mounted central wing support.</p> <p>Wing span segments are minimum length, therefore PASS</p> <p>Wing chord is minimum throughout the existing span, therefore PASS.</p> <p>Wing thickness is minimum throughout the wing's existing span and at a point along the existing chord, therefore PASS.</p>
	FAIL	PASS	PASS	<p>Wing span is split by nose.</p> <p>Wing span segments are less than minimum length at trailing edge (rear of wing), therefore FAIL</p> <p>Wing chord is minimum throughout the existing span, therefore PASS.</p> <p>Wing thickness is minimum throughout the wing's existing span and at a point along the existing chord, therefore PASS.</p>
	PASS	PASS	FAIL	<p>Wing span is split by nose.</p> <p>Wing span segments are minimum length, therefore PASS</p> <p>Wing chord is minimum throughout the existing span, therefore PASS.</p> <p>Wing thickness is less than minimum, therefore FAIL.</p>

Front Wing Examples – Multiple Vanes	T8.5.1 Span -2pts per mm	T8.5.2 Chord -1pts per mm	T8.5.3 Thickness -1pts per mm	Remarks
	PASS	FAIL	PASS	<p>Wing span is split by single mounted central wing support.</p> <p>Wing span segments are minimum length (25mm+25mm), therefore PASS</p> <p>Wing chord is minimum throughout the existing span, but Multi vane wings do not overlap FAIL.</p> <p>Wing thickness is minimum throughout the wing's existing span and at a point along the existing chord, therefore PASS.</p>
	FAIL	PASS	PASS	<p>Wing span is split by single mounted central wing support.</p> <p>Wing span segments are less than minimum length at trailing edge (rear of wing), therefore FAIL</p> <p>Wing chord is minimum throughout the existing span, therefore PASS.</p> <p>Wing thickness is minimum throughout the wing's existing span and at a point along the existing chord, therefore PASS.</p>
	PASS	PASS	FAIL	<p>Wing span is split by single mounted central wing support.</p> <p>Wing span segments are minimum length (25mm+25mm), therefore PASS</p> <p>Wing chord is minimum throughout the existing span, therefore PASS.</p> <p>Wing thickness is over the maximum limit, therefore FAIL.</p>

iv. Rear wing compliance examples

The following table shows how penalty points are awarded for rear wing span, chord or thickness dimensions that do not meet the specifications set out in **T9.5.1, T9.5.2, T9.5.3, T9.5.4**:

This is not an exhaustive list of all possible wing configurations.

Rear Wing Examples – Single Vane	T9.5.1 Span -2pts per mm	T9.5.2 Chord -1pt per mm	T9.5.3 Thickness -1pt per mm	T9.5.4 Deviation -1pt per mm	Remarks
	PASS	PASS	PASS	PASS	<p>Wing span is minimum length, therefore PASS.</p> <p>Wing chord is minimum throughout the existing span, therefore PASS.</p> <p>Wing thickness is minimum throughout the wing's existing span and at a point along the existing chord, therefore PASS.</p> <p>Rear wing deviation is below maximum, therefore PASS.</p>
	PASS	PASS	FAIL	PASS	<p>Wing span is minimum length, therefore PASS.</p> <p>Wing chord is minimum throughout the existing span, therefore PASS.</p> <p>Wing thickness is more than maximum, therefore FAIL.</p> <p>Rear wing deviation is below maximum, therefore PASS.</p>
	PASS	FAIL	PASS	FAIL	<p>Wing span is minimum length, therefore PASS.</p> <p>Wing chord is less than minimum length, therefore FAIL.</p> <p>Wing thickness is minimum throughout the wing's existing span and at a point along the existing chord, therefore PASS.</p> <p>Wing deviation exceeds maximum height, therefore FAIL.</p>

Rear Wing Examples – Multiple Vane	T9.5.1 Span -2pts per mm	T9.5.2 Chord -1pt per mm	T9.5.3 Thickness -1pt per mm	T9.5.4 Deviation -1pt per mm	Remarks
	PASS	PASS	PASS	PASS	<p>Wing span is minimum length, therefore PASS.</p> <p>Wing chord is minimum throughout the existing span, therefore PASS.</p> <p>Wing thickness is minimum throughout the wing's existing span and at a point along the existing chord, therefore PASS.</p> <p>Wing deviation is minimum throughout the existing span, therefore PASS.</p>
	PASS	FAIL	PASS	PASS	<p>Wing span is minimum length, therefore PASS.</p> <p>Wing chord is minimum throughout the existing span, but Multi vane wings do not overlap FAIL.</p> <p>Wing thickness is minimum throughout the wing's existing span and at a point along the existing chord, therefore PASS.</p> <p>Wing deviation is minimum throughout the existing span, therefore PASS.</p>
	PASS	FAIL	PASS	FAIL	<p>Wing span is minimum length, therefore PASS.</p> <p>Wing chord is less than minimum length, therefore FAIL.</p> <p>Wing thickness is minimum throughout the wing's existing span and at a point along the existing chord, therefore PASS.</p> <p>Wing deviation exceeds maximum height, therefore FAIL.</p>

v. Wing Overlap

Wing overlap explanation:

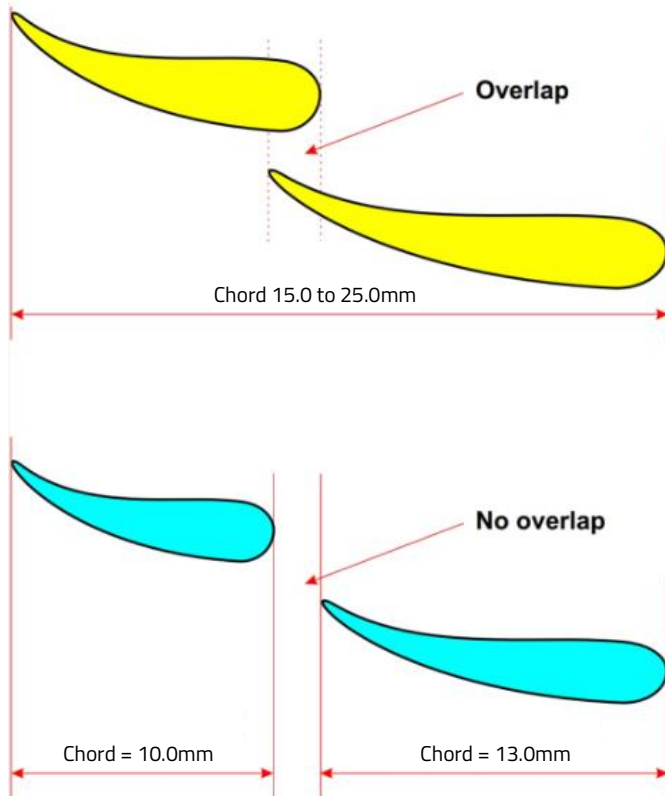

How to check if a gap exists between the elements:

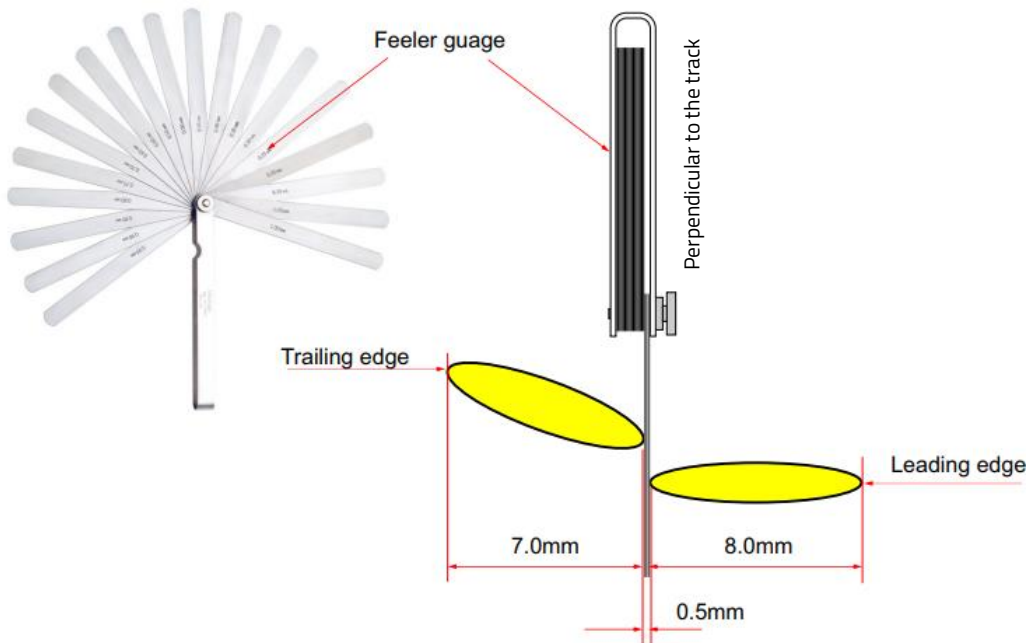

vi. Official Denford Race Power Pack dimensions



This component is available to download as a universal 3D part from the F1 in Schools website. For this part and more free downloads, please visit

<https://www.f1inschools.com/downloads.html>

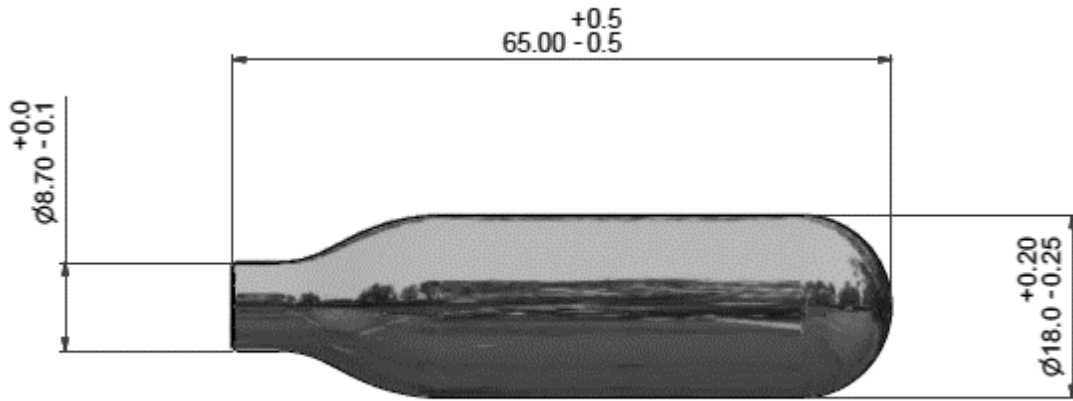

Full weight of RACE Power Pack: between: 28.9g and 29.4g

vii. Car Deceleration System dimensions

The following diagram shows the important dimensions of the Official F1 in Schools Car Deceleration System, which will be available at the Aramco F1® in Schools World Finals 2023.

The dimensions shown indicate the relative spacing between the integrated brushes and the track surface.

Please note: teams have the option to use their own car deceleration systems. Please refer to the Aramco F1® in Schools World Finals 2023 Competition Regulations for full details.

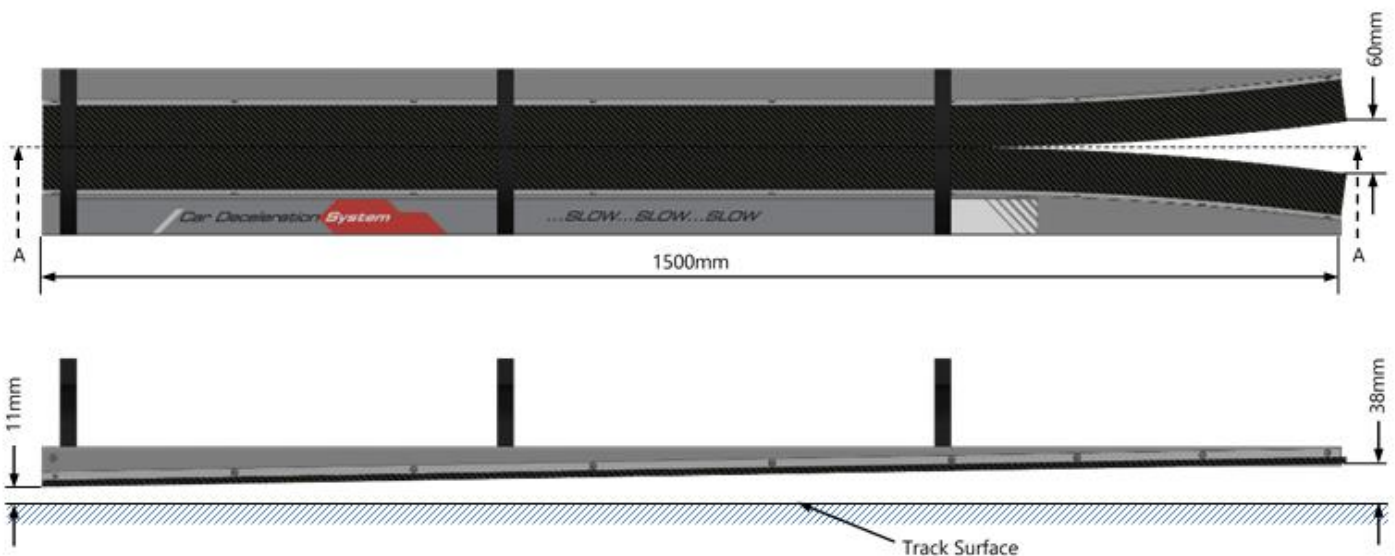

viii. Example of component identification from 2021 World Champions car

Please note: regulation numbers correspond to 2021 Technical Regulations

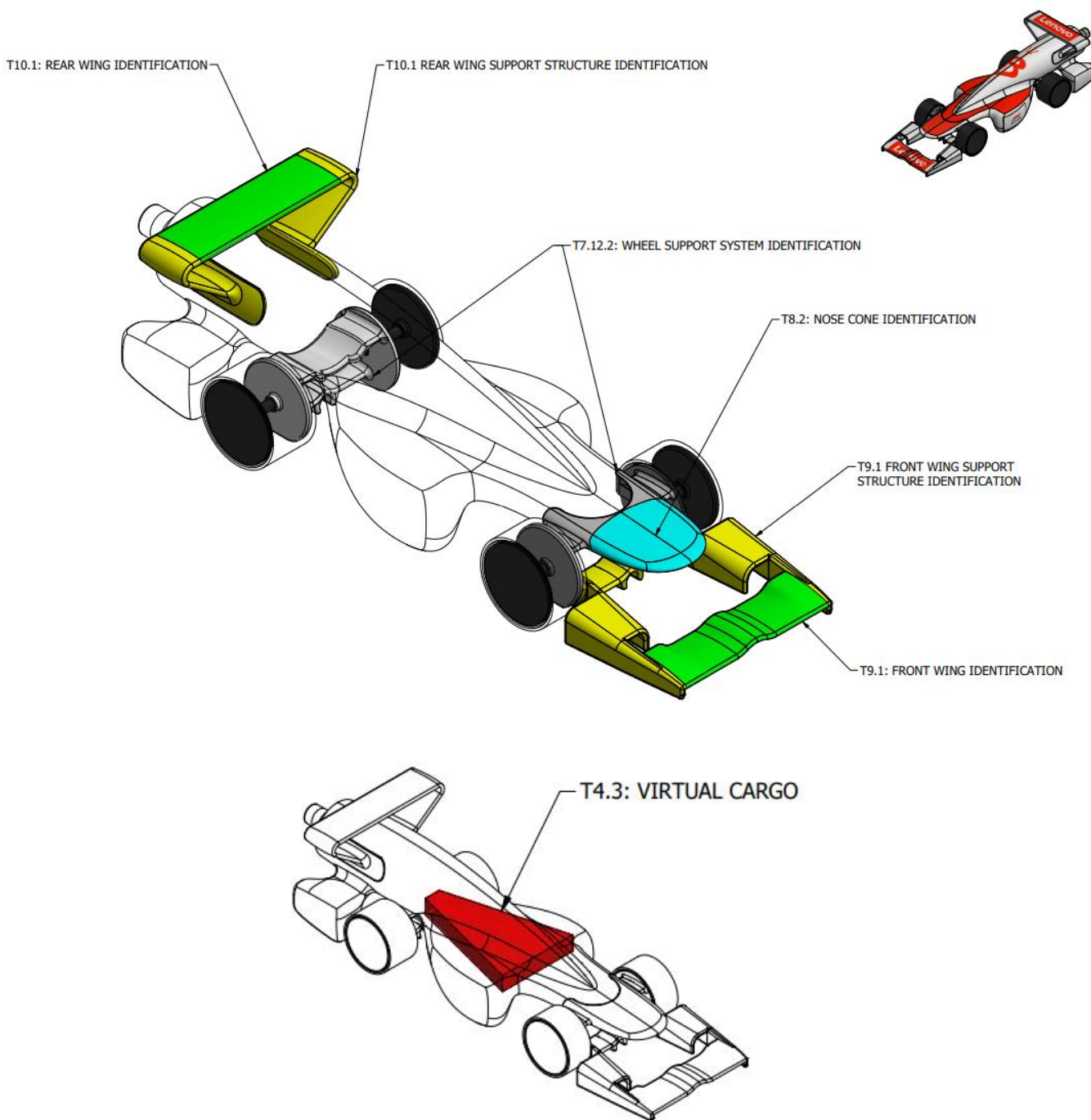

ix. Halo drawings

To accommodate the 'Halo' your car will require a pocket cut to the dimensions in the drawing below using a 6.35mm (1/4") or smaller ball nose tool to a depth of 3.175mm. The centre of the Halo 'Circular notch' for the retardation device is exactly 10.0 mm above the bottom of the pocket. To be effective the centre of the Circular Notch must be 34.0mm ±1.0mm above the track surface. To achieve this the bottom of the pocket must be 24.0mm above the track in the assembled car. *Use the dimensions on the diagrams below to check you have manufactured your Halo correctly.*

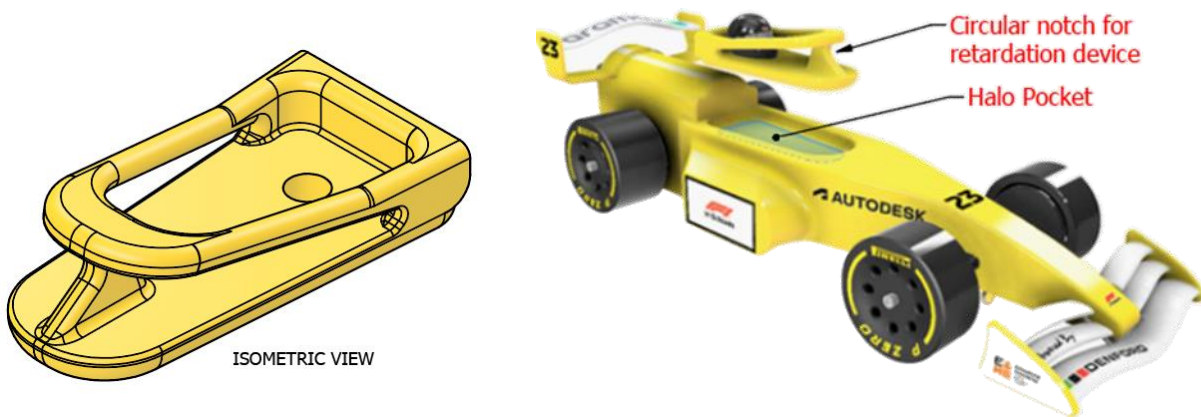
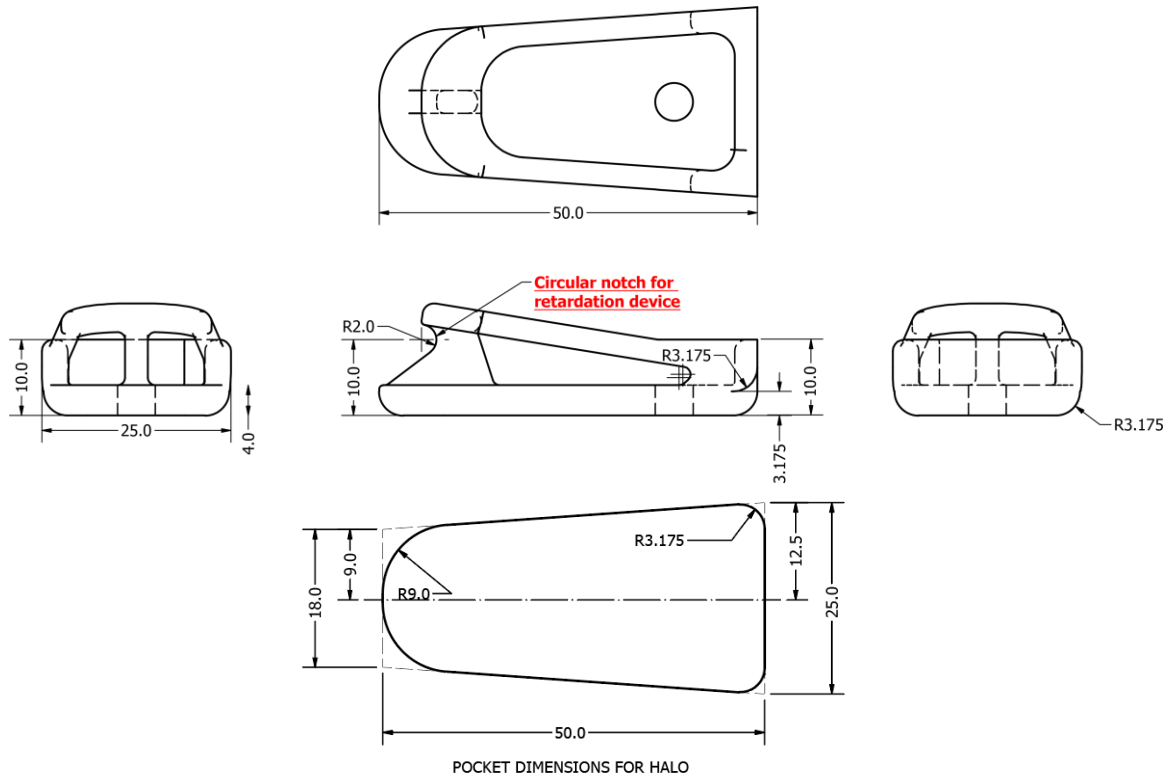



**Please make sure you have also read the
Aramco F1® in Schools World Finals 2023
Competition Regulations**

For Official Technical & Competition Regulations Clarifications please email us at rules@f1inschools.com. All official clarifications will be posted in our official [website](#).

**Work hard,
see you at the
World Finals!**

If you need any help at all, just get in touch with us:

F1® in Schools

**+44 (0)20 7344 5390
rules@f1inschools.com
www.f1inschools.com**